

INSTRUCTION MANUAL

RA 19-4B RACK ADAPTER

HOT SWAP RACK ADAPTER FOR HSF SERIES POWER SUPPLIES

KEPCO INC.
An ISO 9001 Company.

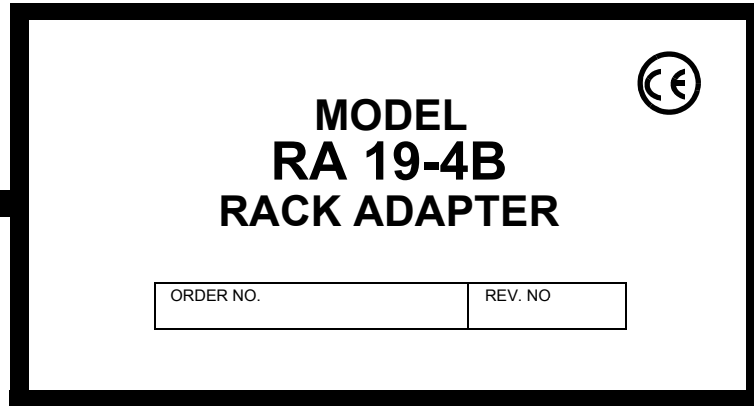

IMPORTANT NOTES:

- 1) This manual is valid for the following Model and associated serial numbers:

MODEL	SERIAL NO.	REV. NO.
-------	------------	----------
- 2) A Change Page may be included at the end of the manual. All applicable changes and revision number changes are documented with reference to the equipment serial numbers. Before using this Instruction Manual, check your equipment serial number to identify your model. If in doubt, contact your nearest Kepco Representative, or the Kepco Documentation Office in New York, (718) 461-7000, requesting the correct revision for your particular model and serial number.
- 3) The contents of this manual are protected by copyright. Reproduction of any part can be made only with the specific written permission of Kepco, Inc.

Data subject to change without notice.

©2006, KEPCO, INC
P/N 243-0955R1



KEPCO, INC. ● 131-38 SANFORD AVENUE ● FLUSHING, NY. 11352 U.S.A. ● TEL (718) 461-7000 ● FAX (718) 767-1102
email: hq@kepcopower.com ● World Wide Web: <http://www.kepcopower.com>

TABLE OF CONTENTS

SECTION	PAGE
SECTION 1 - INTRODUCTION	
1.1	Scope of Manual..... 1-1
1.2	General Description 1-1
1.3	Electrical 1-1
1.4	Mechanical..... 1-2
1.5	Accessories 1-2
1.6	Options 1-2
SECTION 2 - INSTALLATION	
2.1	Unpacking and Inspection 2-1
2.2	Configuring the Rack Adapter..... 2-1
2.3	Rack Adapter Keying Instructions..... 2-1
2.3.1	Disassembly to Gain Access to Interior Components..... 2-1
2.3.2	Establishing Key Positions..... 2-2
2.4	Slot Configuration 2-3
2.4.1	Independent Operation 2-4
2.4.1.1	Independent Operation - Local Sensing Using Internal DIP switches..... 2-5
2.4.1.2	Independent Operation - Local Sensing Using External Wiring 2-6
2.4.1.3	Independent Operation - Remote Sensing..... 2-7
2.4.2	Parallel Operation 2-8
2.4.2.1	Parallel DC OUTPUT Connections 2-8
2.4.2.2	Parallel Current Share Connections..... 2-8
2.4.2.2.1	Parallel Current Share - Internal DIP Switches 2-9
2.4.2.2.2	Parallel Current Share - External Wiring 2-10
2.4.2.3	Sense Connections for Parallel Configurations..... 2-10
2.4.2.3.1	Parallel Configuration Using DIP Switches to Connect Sense Lines in Parallel and External Wires to Configure Local Sensing 2-11
2.4.2.3.2	Parallel Configurations using External Wires to Connect Sense Lines in Parallel and External Wires to Configure Local Sensing 2-12
2.4.2.3.3	Parallel Configurations using DIP Switches to Connect Sense Lines in Parallel and External Wires to Configure Remote Sensing 2-13
2.4.2.3.4	Parallel Configurations using External Wires to Connect Sense Lines in Parallel and External Wires to Configure Remote Sensing 2-14
2.4.3	Series Operation 2-15
2.4.4	Alarm Configurations 2-16
2.4.4.1	N.O. Alarm Line (Close on Failure)..... 2-16
2.4.4.1.1	Close on Failure Using Internal Dip Switches 2-16
2.4.4.1.2	Close on Failure Using External Wiring at I/O Mating Connector 2-18
2.4.4.2	N.C. Alarm Line (Open on Failure)..... 2-19
2.4.4.2.1	Open on Failure Using Internal Dip Switches..... 2-19
2.4.4.2.2	Open on Failure Using External Wiring of I/O Mating Connector..... 2-20
2.5	Terminations 2-21
2.6	Cooling..... 2-21
2.7	Installation..... 2-21
2.8	Wiring Instructions 2-21
2.8.1	Safety Grounding 2-21
2.8.2	Source Power Connections 2-22
2.8.3	Control Signal Connections 2-22
2.8.4	Output Load Connections 2-23
2.8.4.1	Parallel/Redundant Operation 2-23
2.8.4.2	Series/Independent Operation 2-23
2.8.4.3	Mixed Operation..... 2-23
2.9	Installing/Removing HSF Power Supplies 2-24
2.10	Shipping..... 2-24

LIST OF FIGURES

FIGURE	TITLE	PAGE
1-1	RA 19-4B Rack Adapter.....	iii
1-2	RA 19-4B Rack Adapter with HSF Power Supplies Installed.....	1-1
1-3	RA 19-4B Interconnections, Simplified Diagram.....	1-2
1-4	RA 19-4B Rack Adapter Rear Panel.....	1-3
1-5	Mechanical Outline Drawing, RA 19-4B Rack Adapter.....	1-4
2-1	Backplate Assembly, Interior View.....	2-2
2-2	Independent Operation, Local Sensing for PS1 and PS2 using Internal DIP switches, Simplified Diagram.....	2-5
2-3	Independent Operation, Local Sensing for PS1 and PS2 using External Jumpers at I/O Mating Connector, Simplified Diagram.....	2-6
2-4	Independent Operation, Remote Sensing for PS1 and PS2 using External Wiring at I/O Mating Connector, Simplified Diagram.....	2-7
2-5	Parallel Outputs Using Internal DIP Switches to Parallel sense lines and current share, PS1 and PS2 (Typical), Simplified Diagram.....	2-9
2-6	Typical Parallel Connections Using External Wires for Local Sensing and DIP switches to parallel sense wires.....	2-11
2-7	Typical Parallel Connections using External Wires for Local Sensing and I/O Mating Connector Jumpers to Parallel sense wires.....	2-12
2-8	Typical Parallel Connections, Remote Sensing using DIP Switches to Parallel Sense Wires.....	2-13
2-9	Typical Parallel Connections, Remote Sensing using I/O Mating Connector Jumpers to Parallel Sense Wires.....	2-14
2-10	Series Configuration, Simplified Diagram.....	2-15
2-11	Close on Failure Alarm Configuration Using Internal Dip Switches, Simplified Diagram.....	2-17
2-12	Close on Failure Alarm Configuration Using External Wiring at I/O Mating Connector, Simplified Diagram.....	2-18
2-13	Open on Failure Alarm Configuration Using Internal Dip Switches, Simplified Diagram.....	2-19
2-14	Open on Failure Alarm Configuration Using External Wiring at I/O Mating Connector, Simplified Diagram.....	2-20

LIST OF TABLES

TABLE	TITLE	PAGE
1-1	Compatible HSF Power Supplies.....	1-3
1-2	RA 19-4B Accessories.....	1-3
2-1	Equipment Supplied.....	2-1
2-2	Configuration DIP Switch Functions.....	2-3

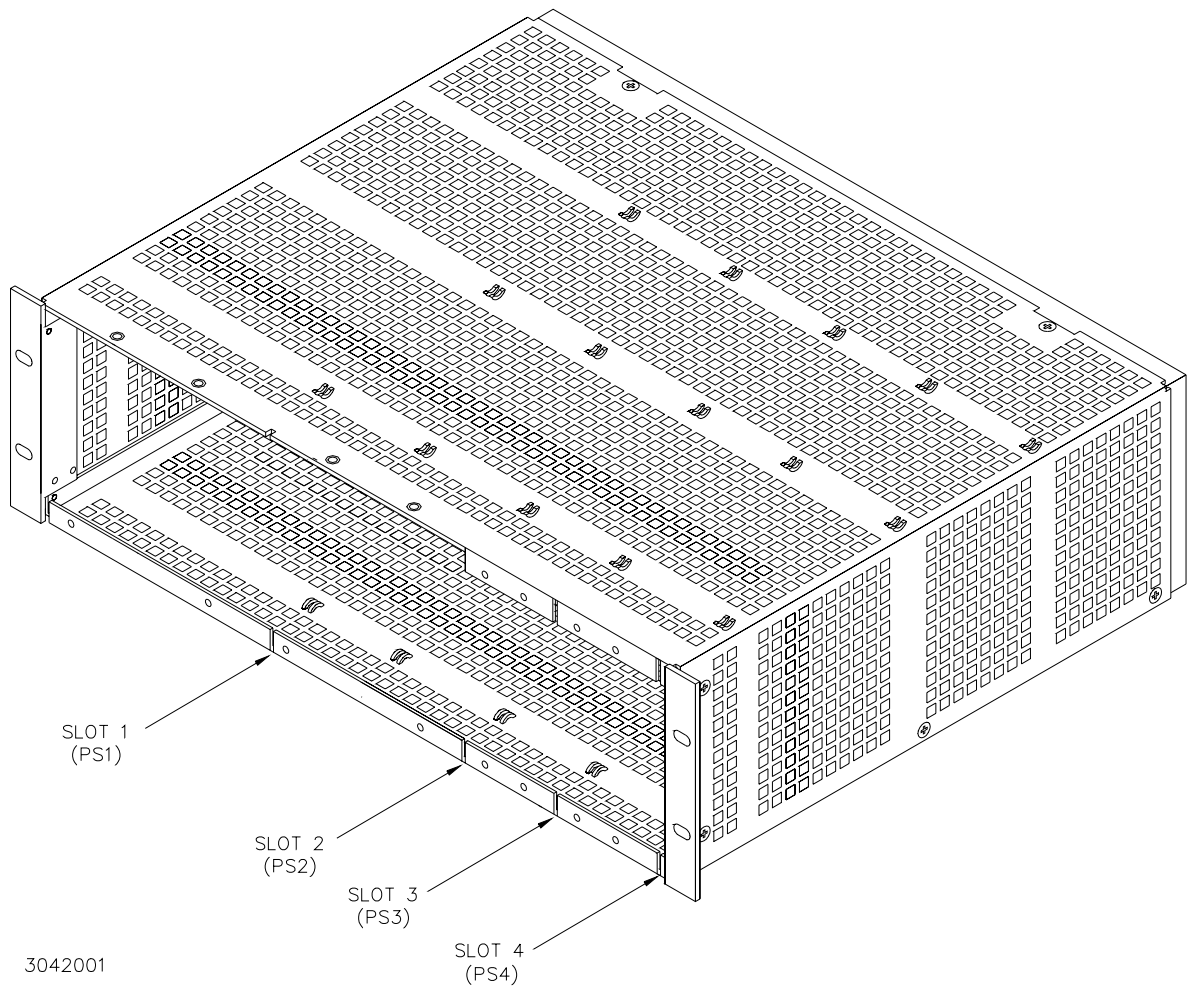

FIGURE 1-1. RA 19-4B RACK ADAPTER

SECTION 1 - INTRODUCTION

1.1 SCOPE OF MANUAL

This manual contains instructions for the installation and operation of the RA 19-4B plug-in rack adapter (Figure 1-1) used with HSF Series power supplies, manufactured by Kepco, Inc., Flushing, New York, U.S.A.

1.2 GENERAL DESCRIPTION

Kepco Series RA 19-(X)B rack adapters are specifically designed for the installation of Kepco HSF Series Power Supplies into 19-inch EIA standard equipment racks. The RA 19-4B Model accommodates up to two 350 Watt (1/3 rack) and four 50W, 100W (1/8 rack) or 150W (1/6 rack) HSF power supplies (Figure 1-2).

NOTE: Model RA 19-5B can accommodate one 350 Watt modules and up to four 50 Watt (1/8 rack), 100 Watt (1/8 rack) or 150 Watt (1/6 rack) modules; contact Kepco Applications Engineering for assistance with non-standard configurations.

The rack adapter is user-configurable for parallel, series, or independent power supply operation. Forced current sharing and OR'ing diodes for N+1 redundancy are built into the HSF power supplies. User-configurable keying ensures that only the correct power supply can be installed in a keyed slot.

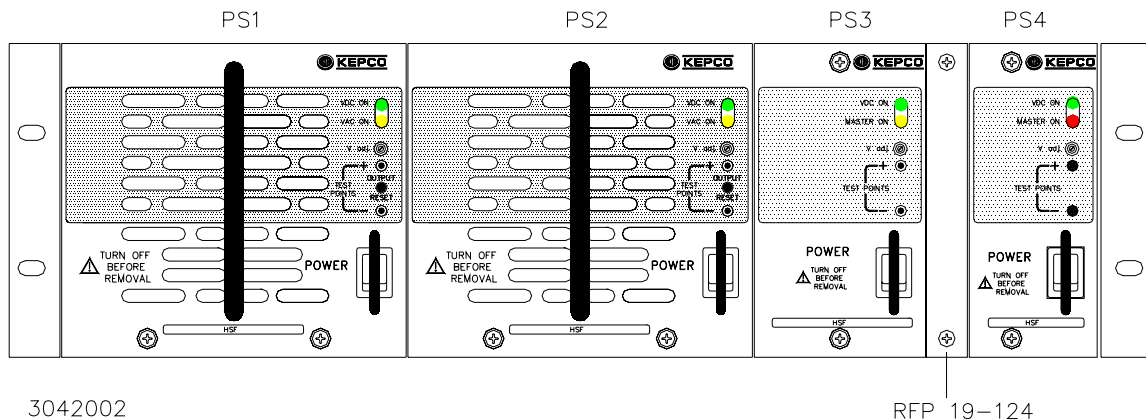
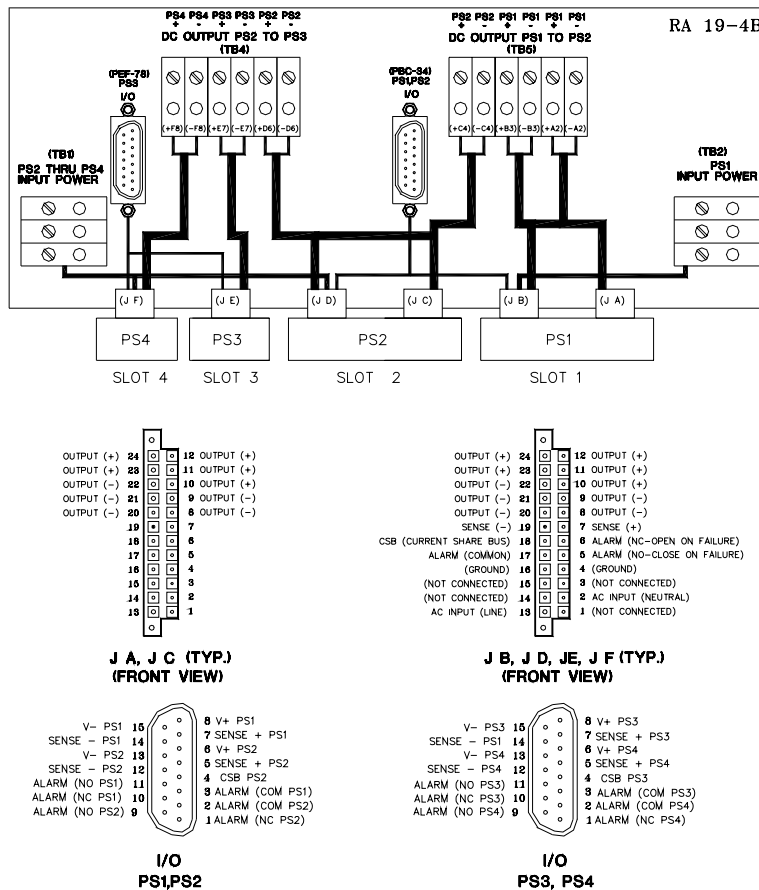

FIGURE 1-2. RA 19-4B RACK ADAPTER WITH HSF POWER SUPPLIES INSTALLED

1.3 ELECTRICAL

An internal PCB back plate mounts connectors which interface directly with the power and signal connectors of HSF Series power supplies, permitting hot swappable insertion and extraction. The other side of the back plate assembly, available from the rear, contains the fixed power and signal connections. Figure 1-3 illustrates the interconnections provided by the RA 19-4B Rack Adapter. Dual input terminal blocks on the back plate assembly (Figure 1-4) distribute input power to each of the three power supplies.

All mechanical and electrical specifications are contained in the mechanical outline drawing: Figure 1-5



3042003

FIGURE 1-3. RA 19-4B INTERCONNECTIONS, SIMPLIFIED DIAGRAM

1.4 MECHANICAL

The rack adapter is equipped with mounting ears for mounting in EIA standard 19-inch racks. For mounting in non-standard racks, consult Kepco Applications Engineering. The rack adapter is not configured for slides. Optional blank filler panels (see Table 1-2) are available if the full complement of power supplies is not utilized.

Mechanical dimensions, material, and finish of the RA 19-4B Rack Adapter is provided in Figure 1-5.

1.5 ACCESSORIES

Accessories for RA 19-4B Rack Adapters are listed in Table 1-2.

1.6 OPTIONS

Table 1-1 below describes the standard model options available with Series RA 19-(X)B rack adapters. For non-standard options, contact Kepco Applications Engineering for assistance.

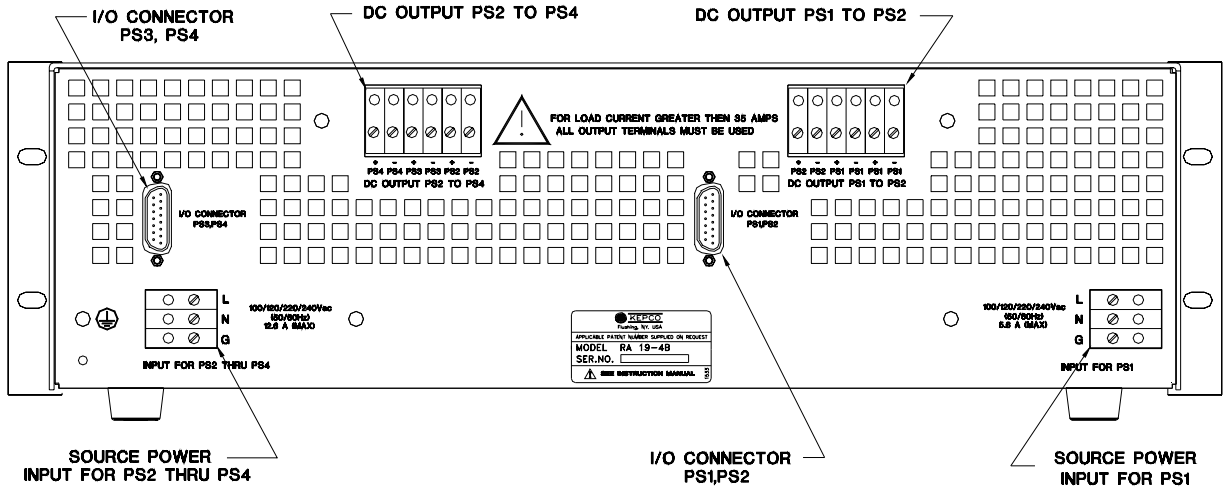

3042004

FIGURE 1-4. RA 19-4B RACK ADAPTER REAR PANEL

TABLE 1-1. COMPATIBLE HSF POWER SUPPLIES

MODEL	1/8 Rack Slots		1/6 Rack Slots		1/3 Rack Slots		
	Total	Compatible HSF Models		Total	Compatible HSF Models	Total	Compatible HSF Models
		50 Watt	100 Watt		150 Watts		350 Watts
RA 19-3B	*			*		3 (max)	HSF3.3-70, HSF5-70, HSF12-30, HSF15-24, HSF24-16, HSF28-13, HSF48-7.5
RA 19-4B	2 (max)	HSF5-10, HSF12-4.2, HSF15-3.4, HSF24-2.1, HSF48-1	HSF5-20, HSF12-8.3, HSF15-6.6, HSF24-4.2, HSF28-3.5, HSF48-2	2 (max)	HSF5-30, HSF12-12, HSF15-10, HSF24-6, HSF28-5, HSF48-2.8	2 (max)	HSF3.3-70, HSF5-70, HSF12-30, HSF15-24, HSF24-16, HSF28-13, HSF48-7.5
RA 19-5B	4 (max)	HSF5-10, HSF12-4.2, HSF15-3.4, HSF24-2.1, HSF48-1	HSF5-20, HSF12-8.3, HSF15-6.6, HSF24-4.2, HSF28-3.5, HSF48-2	4 (max)	HSF5-30, HSF12-12, HSF15-10, HSF24-6, HSF28-5, HSF48-2.8	1 (max)	HSF3.3-70, HSF5-70, HSF12-30, HSF15-24, HSF24-16, HSF28-13, HSF48-7.5
RA 19-6B	*			6 (max)	HSF5-30, HSF12-12, HSF15-10, HSF24-6, HSF28-5, HSF48-2.8		
RA 19-7B	7 (max)	HSF5-10, HSF12-4.2, HSF15-3.4, HSF24-2.1, HSF48-1	HSF5-20, HSF12-8.3, HSF15-6.6, HSF24-4.2, HSF28-3.5, HSF48-2	4 (max)	HSF5-30, HSF12-12, HSF15-10, HSF24-6, HSF28-5, HSF48-2.8		
RA 19-8B	8 (max)	HSF5-10, HSF12-4.2, HSF15-3.4, HSF24-2.1, HSF48-1	HSF5-20, HSF12-8.3, HSF15-6.6, HSF24-4.2, HSF28-3.5, HSF48-2	*			

* Contact Kepco Applications Engineering for assistance with non-standard configurations.

TABLE 1-2. RA 19-4B ACCESSORIES

ACCESSORY	PART NUMBER	USE
Filler Panel (1/6 Rack)	RFP 19-16	Cover one unused 1/6 rack slot.
Filler Panel (1/3 Rack)	RFP 19-13	Cover one unused 1/3 rack slot (includes top bracket)
Filler Panel (1/3 Rack)	RFP 19-26	Cover two unused 1/6 rack slots
Filler Panel (2/3 Rack)	RFP 19-23	Cover two unused 1/3 rack slots (includes top brackets).
Filler Panel (1/24 Rack)	RFP 19-124	Cover gap if 1/8 rack unit used in 1/6 rack slot (See NOTE)

NOTE: If mounting holes for filler panel are not visible with 1/8 unit installed, order RFP 19-24

Dimensions are in inches, [dimensions in brackets are in millimeters].

Tolerance: $\pm 1/64"$ (0.4) between mounting holes; $\pm 1/32"$ (0.8) other dimensions

NOTES:

1. MATERIAL:
 - A) CHASSIS, COVER STEEL CRS #14 GAGE
 - B) BACK COVER ALUMINUM #14 GA.
2. FINISH:
 - A) CHASSIS & COVER: YELLOW CHROMATE.
 - B) FRONT PANEL & ANGLE BKT: KEPSCO GRAY.
 - C) BACK COVER: IRIDITE GOLD
3. RACK OR CABINET MOUNTING: REMOVE (4) PLASTIC FEET
4. DIMENSIONS IN PARENTHESES ARE IN MILLIMETERS.

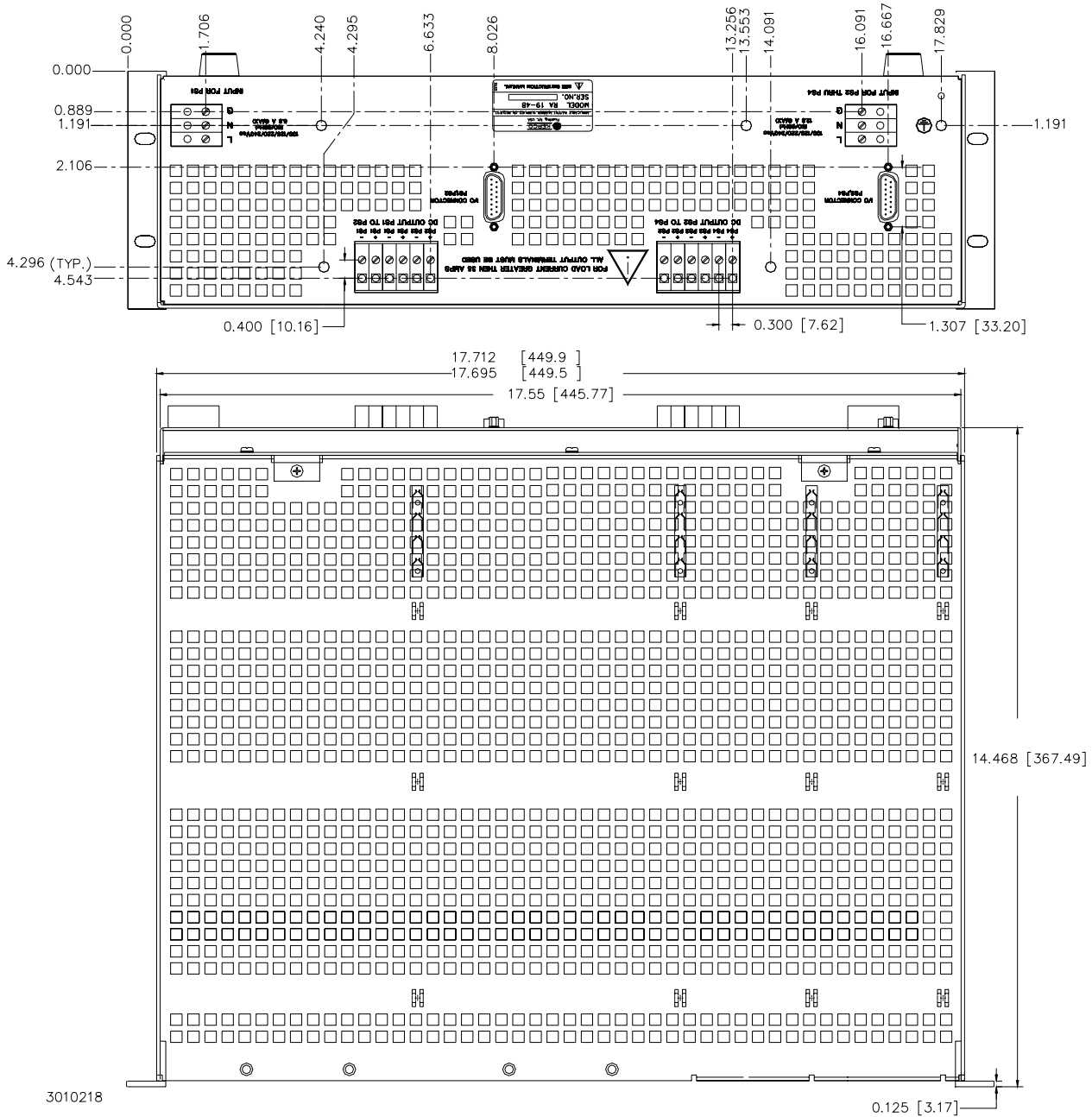

FIGURE 1-5. MECHANICAL OUTLINE DRAWING, RA 19-4B RACK ADAPTER (SHEET 1 OF 2)

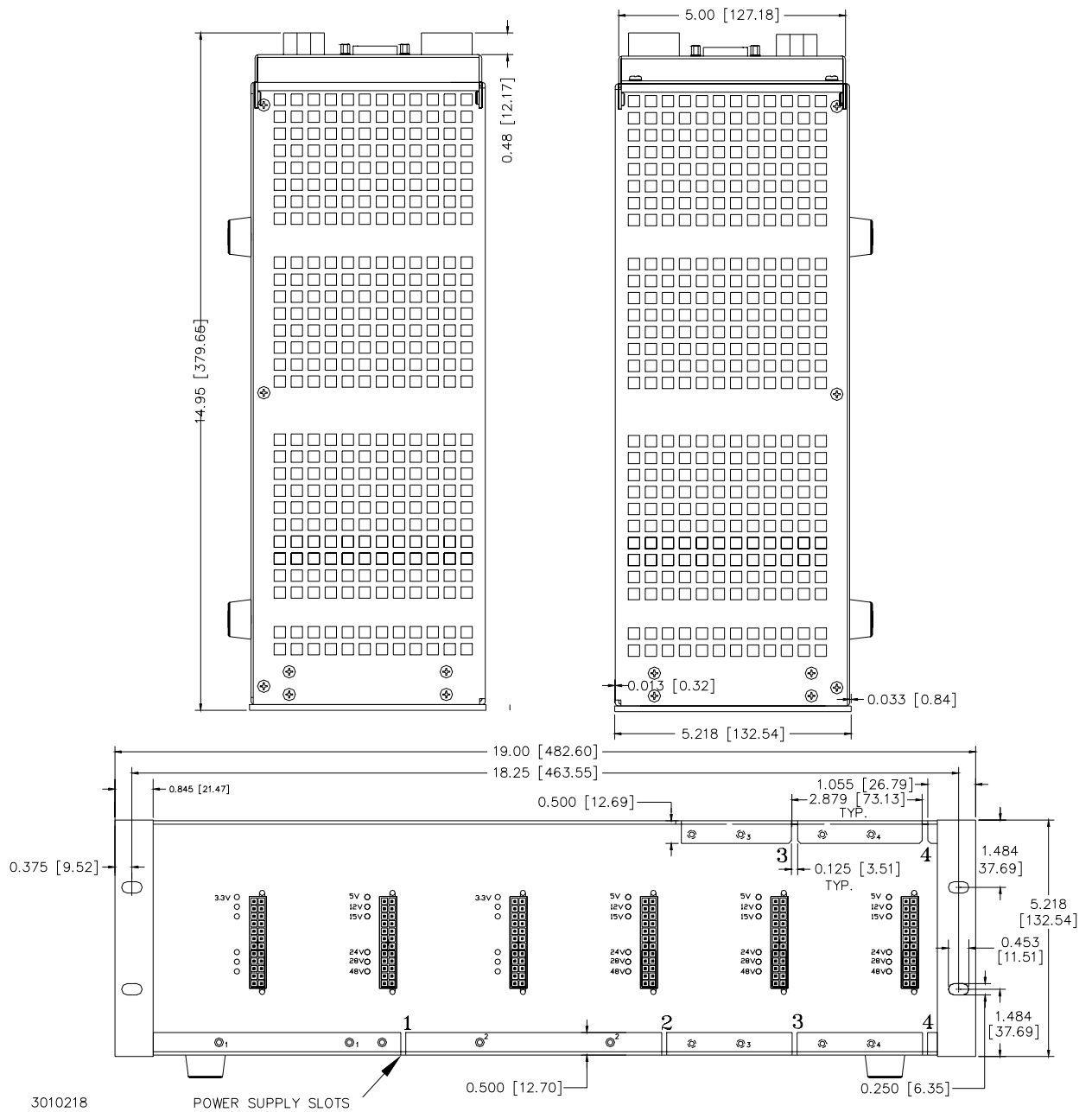

FIGURE 1-5. MECHANICAL OUTLINE DRAWING, RA 19-4B RACK ADAPTER (SHEET 2 OF 2)

SECTION 2 - INSTALLATION

2.1 UNPACKING AND INSPECTION

This equipment has been thoroughly inspected and tested prior to packing and is ready for operation. After careful unpacking, inspect for shipping damage before attempting to operate. If any indication of damage is found, file an immediate claim with the responsible transport service. See Table 2-1 for a list of equipment supplied.

TABLE 2-1. EQUIPMENT SUPPLIED

ITEM	QUANTITY	PART NUMBER
Rack Adapter	1	RA 19-4B
I/O Connector (Mating)	2	142-0449
Line cord (115 V a-c, 15A max, North American style plug, 6 ft.)	2	118-0506
Instruction Manual	1	243-0955
Keying pins	4	108-0305
Hood for I/O Connector (Mating) P/N 142-0449	2	108-0204

2.2 CONFIGURING THE RACK ADAPTER

Prior to installation the rack adapter must be configured by the user. Configuration consists of the following:

- For configurations that use multiple output voltages it is possible to key the rack adapter to accept only a power supply with corresponding keying (see PAR 2.3).
- Configuring slots for independent, parallel, or series operation. This can be done by means of internal DIP switches, or externally by wiring the associated I/O mating connector and DC OUTPUT terminals (see PAR. 2.4).

2.3 RACK ADAPTER KEYING INSTRUCTIONS

Series RA 19-(X)B rack adapters incorporate a keying mechanism to prevent accidental insertion of the incorrect model HSF power supply into any position. The HSF power supplies are keyed by voltage at the factory. The keying mechanism will prevent engagement of any of the HSF power supply's connectors with those on the rack adapter's back plate unless the key and keyway align. The user can configure each power supply position of the rack adapter for the desired voltage in the desired position (see Figure 2-1). First gain access to the interior components (PAR.2.3.1), then position the key as required (PAR. 2.3.2).

NOTE: After removing the rear panel, the keying pins can be accessed through the front of the rack adapter, although it is recommended that the back plate be removed to gain easy access to interior components.

2.3.1 DISASSEMBLY TO GAIN ACCESS TO INTERIOR COMPONENTS

NOTE: All power supplies must be removed prior to disassembly.

1. Remove four spacers securing the two I/O connectors to the rear panel

2. Remove the four screws (two at the top and two at the bottom) securing the rear panel to the chassis and separate the rear panel from the chassis (it is not necessary to remove the ground connection (if present) between the rear panel and the chassis).
3. Remove seven screws (three at the top and four at the bottom) securing the back plate to the chassis and remove the back plate to gain access to the interior components (see Figure 2-1)

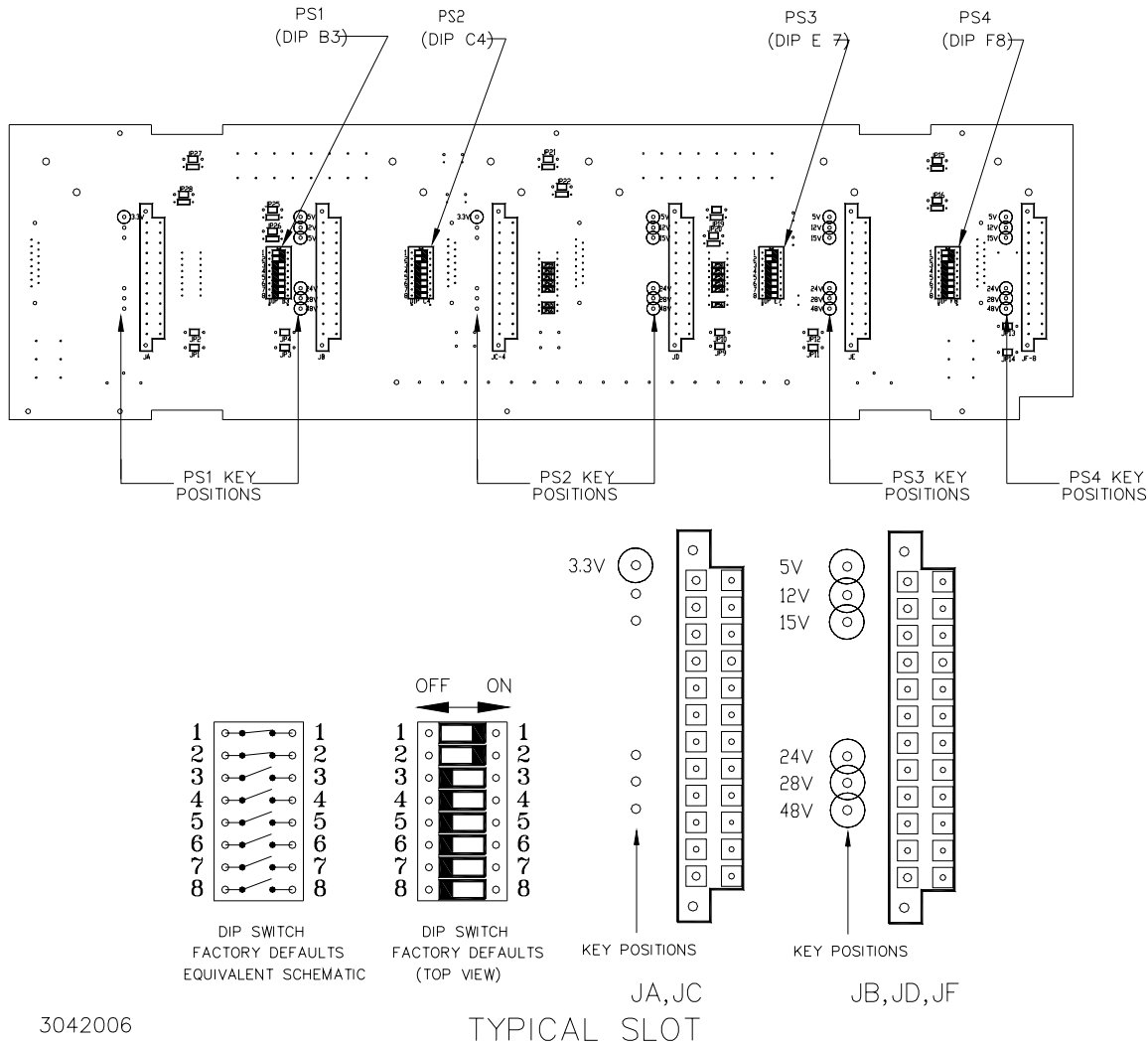

3042006

FIGURE 2-1. BACKPLATE ASSEMBLY, INTERIOR VIEW

2.3.2 ESTABLISHING KEY POSITIONS

To establish the keying of any position, simply insert the key pin from the front and secure with mounting nut at the back plate using two ¼" nutdrivers or deep sockets. RA 19-4B backplate assembly keying is identical to the HSF module keying identified in Figure 2-1 and in the HSF operator's manual. **DO NOT ALTER THE KEYING AT THE POWER SUPPLY.**

2.4 SLOT CONFIGURATION

Configuring slots of the rack adapter for independent, parallel or series operation is accomplished either internally by means of DIP switches associated with each slot (see Figure 2-1), or externally by connecting the appropriate pins of the associated I/O mating connector. DIP switch functions are explained in Table 2-2. Refer to PAR. 2.3.1 to gain access to the DIP switches.

Slot configuration requires the following selection:

1. Select independent (PAR. 2.4.1), parallel (PAR. 2.4.2), or series (PAR. 2.4.3) operation.
2. Select local or remote sensing; PAR. 2.4.1 (independent), 2.4.2, (parallel) or 2.4.3, (series).
3. Optional: Select close-on-failure or open-on-failure alarm (PAR. 2.4.4).

TABLE 2-2. CONFIGURATION DIP SWITCH FUNCTIONS

DIP SWITCH POSITION	FUNCTION	DIP SWITCH SET TO ON (CLOSED)	DIP SWITCH SET TO OFF (OPEN)
NOTE: BOLD TYPE INDICATES FACTORY SETTINGS.			
1, 2	Local / Remote Sensing Selection	Required ON for independent operation with Local Sensing. Position 1 connects V+ to S+, Position 2 connects V- to S- (see PAR. 2.4.1.1).	Position 1 and 2 required OFF for: a) Independent configurations using Remote Sensing (see PAR. 2.4.1.3). b) Independent configurations using Local Sensing with user supplied connections from V+ to S+ and V- to S- (see PAR. 2.4.1.2). c) All parallel configurations (sensing must be established using external wires) (see PAR. 2.4.2.3). d) All series connections (see PAR. 2.4.3).
3, 4	Connect Sense + and - in parallel	Required ON for parallel configurations using DIP switch settings to connect the sense leads in parallel. Position 3 connects +S to adjacent slot +S, Position 4 connects -S to adjacent slot -S (see PAR. 2.4.2.3.1 for local sensing, PAR. 2.4.2.3.3 for remote sensing).	Position 3 and 4 required OFF for all configurations except parallel configurations using DIP switch settings to connect the sense leads in parallel.
5	Current Share	Required ON for parallel operation (connects current share lines in parallel) unless connections are made via external wires (see PAR. 2.4.2.2.1)	Required OFF for a) independent and series configurations. b) Parallel configurations using external wires to connect current share lines in parallel.
6, 7	Close on Failure Alarm	When set to OFF, allows a single alarm to provide failure indication (contact closure between N.O. pin and COM pin) if any one of many power supplies fails (see PAR. 2.4.4.1).	When set to ON, individual power supplies produce closure between I/O connector N.O. and COM pins upon failure (see PAR. 2.4.4.1).
8	Open on Failure Alarm	When set to OFF, allows a single alarm to provide failure indication (contact open between N.C. pin and COM pin) if any one of many power supplies fails (see PAR. 2.4.4.2).	When set to ON, individual power supplies produce open between I/O connector N.C. and COM pins upon failure (see PAR. 2.4.4.2).

2.4.1 INDEPENDENT OPERATION

The rack adapter is preconfigured at the factory for independent operation of all slots. DIP switch positions 3, 4 and 5 associated with each slot must be set to OFF (open) for each power supply to be operated independently.

NOTE: Either local or remote sensing *must* be connected for the HSF power supplies to work properly.

The rack adapter is shipped from the factory with each power supply position configured for local sensing (see Figure 2-2). Sensing for each slot can be configured independently:

- Local sensing using internal DIP switches
- Local sensing using external jumpers connected to the I/O mating connector or the DC OUTPUT terminal block.
- Remote sensing

2.4.1.1 INDEPENDENT OPERATION - LOCAL SENSING USING INTERNAL DIP SWITCHES

The rack adapter slots are preconfigured at the factory for local sensing using internal DIP switches. If a slot has been configured for other than local sensing using DIP switches and it is necessary to reconfigure it for local sensing, simply set positions 1 and 2 of the DIP switch associated with that slot to ON (closed). External sensing connections must be removed. When set to ON (closed) DIP switch position 1 connects (V+) to (S+) and position 2 connects (V-) to (S-). See Figure 2-1 for DIP switch locations. Figure 2-2 illustrates local sensing of PS1 and PS2 by setting positions 1 and 2 of internal DIP switches B3 and C4 to ON (closed); positions 3 and 4 must be set to OFF (open). Position 5 (current share) must be set to OFF and positions 6, 7, and 8 (alarms) can be configured per PAR. 2.4.4.

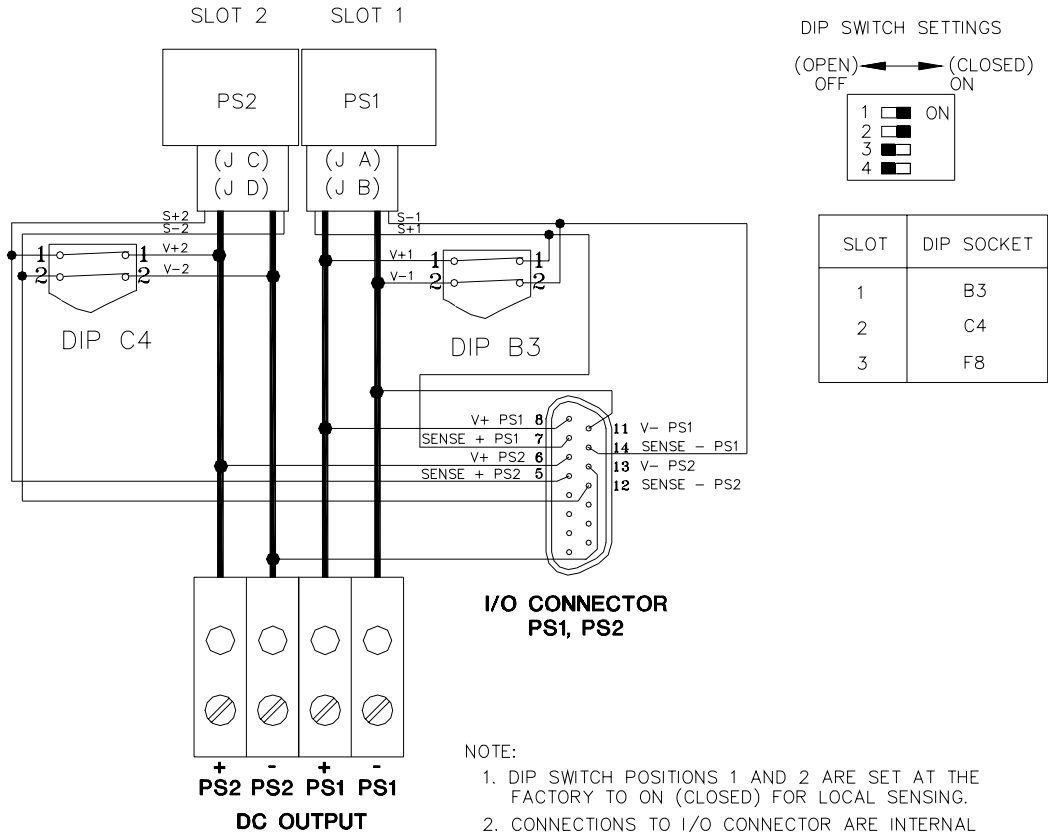

3041878

FIGURE 2-2. INDEPENDENT OPERATION, LOCAL SENSING FOR PS1 AND PS2 USING INTERNAL DIP SWITCHES, SIMPLIFIED DIAGRAM

2.4.1.2 INDEPENDENT OPERATION - LOCAL SENSING USING EXTERNAL WIRING

To configure a slot for local sensing using external wiring, first set internal DIP switch positions 1 and 2 of the DIP switches associated with that slot to OFF (open).

External local sensing is accomplished by connecting (V+) to (S+) and (V-) to (S-). This can be done at either the mating I/O connector supplied (see Table 2-1) or the DC OUTPUT terminal block. See Figure 2-1 for DIP socket locations. Figure 1-3 illustrates I/O connector pin assignments. Figure 2-3 illustrates local sensing of PS1 and PS2 using external jumpers connected to the I/O mating connector.

NOTE: The internal DIP switch settings established at the factory for positions 1 and 2 of the associated DIP switch MUST be changed to OFF (open) if this option is chosen.

Positions 3 and 4 (connecting sense lines in parallel) and Position 5 (current share) must be set to OFF. Configure Positions 6, 7, and 8 (alarms) per PAR. 2.4.4.

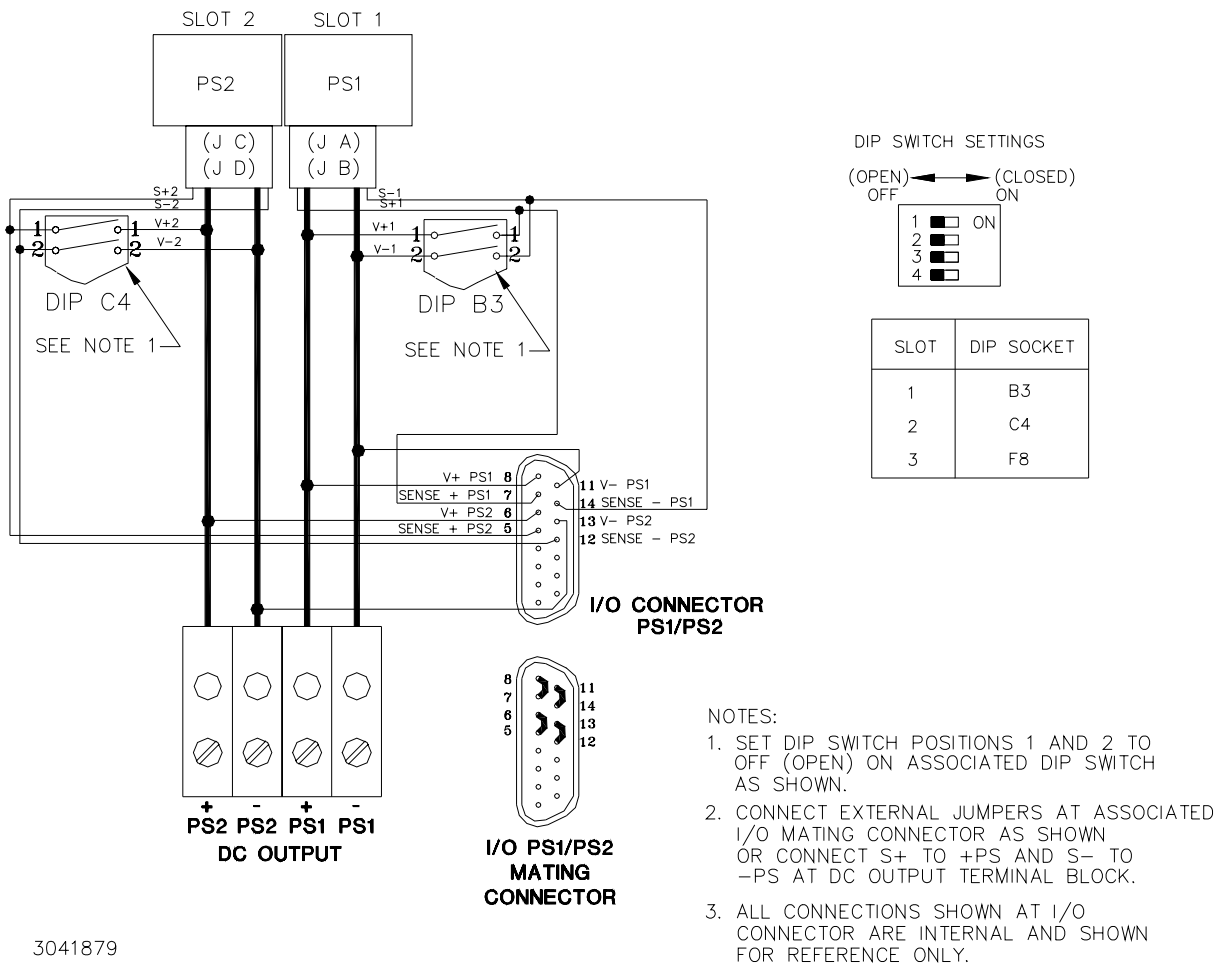

3041879

FIGURE 2-3. INDEPENDENT OPERATION, LOCAL SENSING FOR PS1 AND PS2 USING EXTERNAL JUMPERS AT I/O MATING CONNECTOR, SIMPLIFIED DIAGRAM

2.4.1.3 INDEPENDENT OPERATION - REMOTE SENSING

Remote sensing is accomplished by connecting +Load to (S+) and -Load to (S-). Figure 2-4 illustrates remote sensing for PS1 and PS2 using wires connected to the I/O mating connector.

NOTE: The internal DIP switch settings established at the factory for positions 1 and 2 of the associated DIP switch MUST be changed to OFF (open) if this option is chosen.

Positions 3 and 4 (connecting sense lines in parallel) and Position 5 (current share) must be set to OFF. Configure Positions 6, 7, and 8 (alarms) per PAR. 2.4.4.

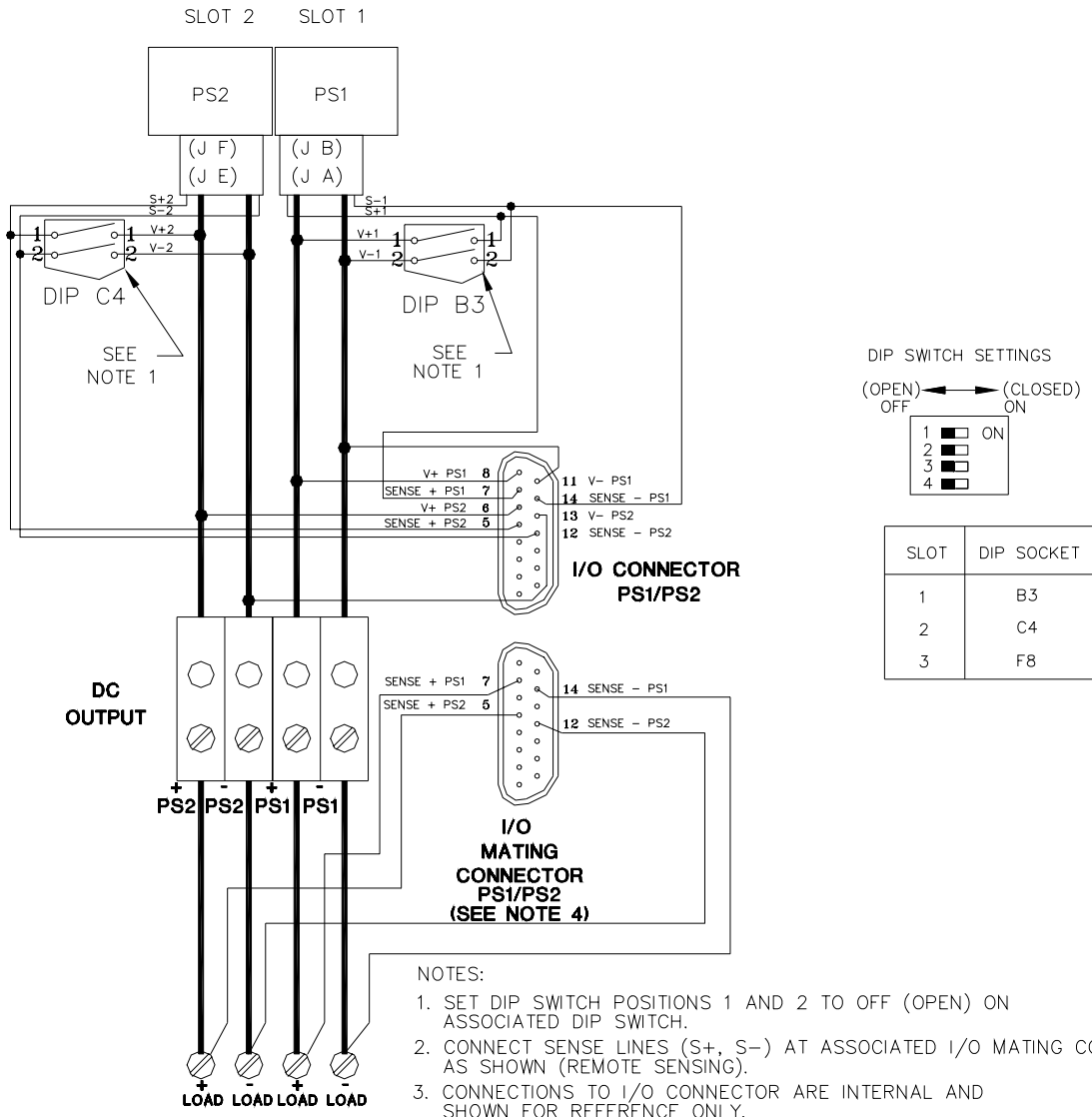

3041880

FIGURE 2-4. INDEPENDENT OPERATION, REMOTE SENSING FOR PS1 AND PS2 USING EXTERNAL WIRING AT I/O MATING CONNECTOR, SIMPLIFIED DIAGRAM

2.4.2 PARALLEL OPERATION

Identical HSF power supplies can be connected in parallel to provide redundant operation or increased output current to a common load. The power leads must be connected in parallel externally (see PAR. 2.8.4.1). (Configurations using internal parallel busing are also possible; consult Kepco's Applications Engineering for details.) Three things must be considered when configuring the rack adapter for parallel operation:

- DC OUTPUT
- CURRENT SHARE
- SENSE

2.4.2.1 PARALLEL DC OUTPUT CONNECTIONS

The power leads must be connected in parallel externally (see PAR. 2.8.4.1). DC Output V(+) and V(-) must be connected in parallel at the DC OUTPUT terminal block (see Figures 2-5 through 2-9).

2.4.2.2 PARALLEL CURRENT SHARE CONNECTIONS

The Current Share pins of the HSF power supplies must be connected together for parallel operation. This can be done either internally using the DIP switches to configure adjacent slots in parallel (PAR 2.4.2.2.1), or externally by wiring the I/O mating connector for configuring slots 2 and 3 (PAR. 2.4.2.2.2).

2.4.2.2.1 PARALLEL CURRENT SHARE - INTERNAL DIP SWITCHES

To configure adjacent slots, use the internal DIP switches to connect the Current Share bus. Using internal DIP switches permits only adjacent power supplies be connected in parallel. (i.e., PS1 and PS2 FOR HSF 350W units and PS3 and PS4 for HSF 50W, 100W or 150W units.

CAUTION: HSF 50W, 150W or 150W units can not be connected in parallel with 350W units.

To connect the current share lines locate the applicable DIP switches: C4 for HSF 350W units and F8 for HSF 50W, 100W or 150W units (see Figure 2-1) and set position 3, 4, 5 to ON (closed). The example illustrated in Figure 2-5 shows two 350W units (slot 1 and slot 2) connected in parallel using internal DIP switches to configure the current share bus, enabled via position 5 of DIP switch C4 for slots 1/2 or F8 for slots 3/4.

NOTE: If internal DIP switch positions 3, 4 are closed (ON), use only one pair of sense lines to monitor voltage.

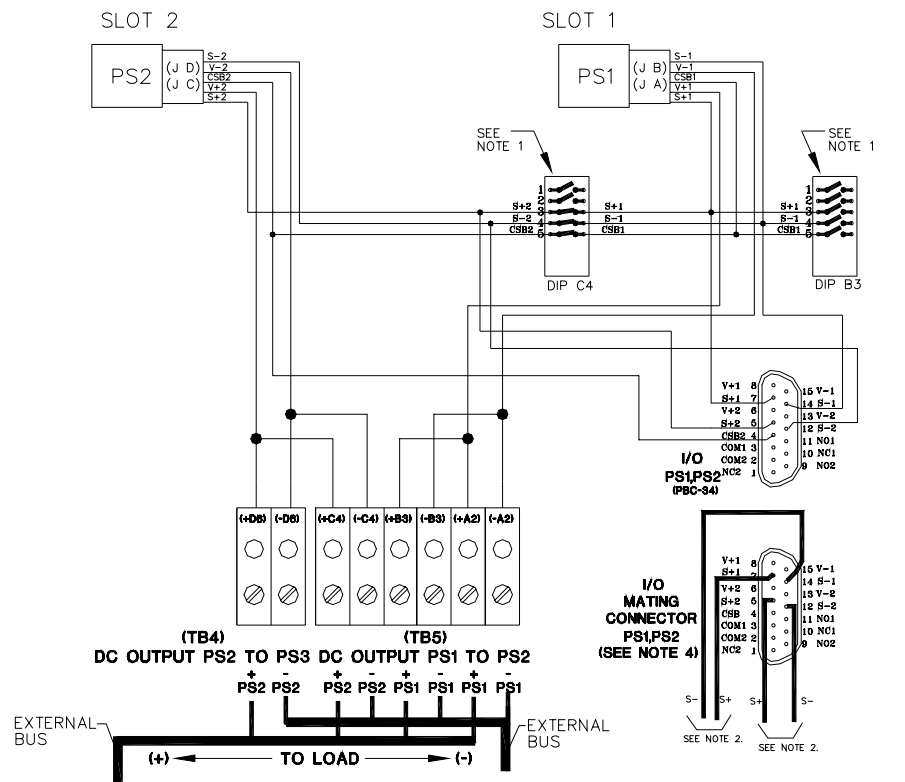

NOTES:

- DIP SWITCH SETTINGS FOR PARALLEL OPERATION :
 POSITIONS 1 AND 2 OF DIP SWITCHES C4 AND B3 MUST BE SET TO OFF (OPEN).
 POSITIONS 3, 4 AND 5 OF DIP SWITCH C4 MUST BE SET TO ON (CLOSED).
 POSITIONS 3, 4, AND 5 OF DIP SWITCH B3 ARE NOT CONNECTED, THEIR SETTING IS IRRELEVANT.
- CONNECT ONLY ONE PAIR OF SENSE LINES (S+, S-) EITHER AT I/O MATING CONNECTOR MONITOR PINS (V+, V-) OR AT DC OUTPUT TERMINAL BLOCK (LOCAL SENSE), OR AT AT THE LOAD (REMOTE SENSE); REFER TO PAR. 2.4.2.3.
- CONNECTIONS TO I/O CONNECTOR ARE INTERNAL AND SHOWN FOR REFERENCE ONLY.
- I/O MATING CONNECTOR VIEWED FROM FRONT (MATING FACE) FOR EASE OF LOCATING CORRESPONDING I/O CONNECTOR PINS.

3042007

FIGURE 2-5. PARALLEL OUTPUTS USING INTERNAL DIP SWITCHES TO PARALLEL SENSE LINES AND CURRENT SHARE, PS1 AND PS2 (TYPICAL), SIMPLIFIED DIAGRAM

2.4.2.2.2 PARALLEL CURRENT SHARE - EXTERNAL WIRING

Due to current share bus incompatibility between HSF 350W units and the 50W, 100W and 150W units, using external wiring for parallel current share is not necessary. Parallel current share bus configuration must be accomplished using the DIP switches (see PAR. 2.4.2.2.1).

2.4.2.3 SENSE CONNECTIONS FOR PARALLEL CONFIGURATIONS

NOTE: HSF power supply sense lines **MUST** be connected to the respective output terminals; otherwise the power supplies will not work.

For parallel configurations the sense lines must be connected in parallel. This can be accomplished either by using the DIP switches (positions 3 and 4 set to ON) or by setting the DIP switch positions 3 and 4 to OFF and using external wires. When configuring units to work in parallel, the current share bus (PAR. 2.4.2.2) must also be configured.

For local sensing (at the rack adapter) connect the sense lines in parallel using either the DIP switches or external jumpers, then connect one +S and one –S from the I/O mating connector to the DC OUTPUT terminal block using short jumpers.

For remote sensing (at the load) connect the sense lines in parallel using either the DIP switches or external jumpers to connect the sense lines in parallel, then connect one +S and one –S from the I/O connector to the load using external wires.

For both local and remote sensing Positions 1 and 2 of *each* DIP switch in the parallel configuration must be set to OFF (open); refer to Figure 2-1 to identify the DIP switch associated with a corresponding slot.

See the following paragraphs for more details:

- PAR. 2.4.2.3.1: Parallel configurations using DIP switches to connect the sense lines in parallel and external wires to configure local sensing.
- PAR. 2.4.2.3.2: Parallel configurations using external wires to connect the sense lines in parallel and external wires to configure local sensing.
- PAR. 2.4.2.3.3: Parallel configurations using DIP switches to connect the sense lines in parallel and external wires to configure remote sensing.
- PAR. 2.4.2.3.4: Parallel configurations using external wires to connect the sense lines in parallel and external wires to configure remote sensing.

2.4.2.3.1 PARALLEL CONFIGURATION USING DIP SWITCHES TO CONNECT SENSE LINES IN PARALLEL AND EXTERNAL WIRES TO CONFIGURE LOCAL SENSING

Figure 2-6 is a simplified diagram of a typical parallel configuration using local sensing via external wires to connect V(+) to S(+), V(-) to S(-) and DIP switch settings to connect the sense leads in parallel. This configuration requires the following:

1. For each supply in parallel set DIP switch positions 1 and 2 to OFF (open) (see Figure 2-1).
2. For each DIP switch between parallel-connected slots (C4 and F8), set DIP switch positions 3 and 4 to ON (closed) to connect sense leads in parallel (see Figure 2-1).
3. For each DIP switch between parallel-connected slots configure position 5 to connect the current share bus by referring to PAR. 2.4.2.2.
4. Configure Positions 6, 7, and 8 (alarms) of each DIP switch per PAR. 2.4.4.
5. Connect wire between I/O mating connector pin Sense (+) and corresponding power supply V(+) terminal at DC OUTPUT terminal block.
6. Connect wire between I/O mating connector pin Sense (-) and corresponding power supply V(-) terminal at DC OUTPUT terminal block.

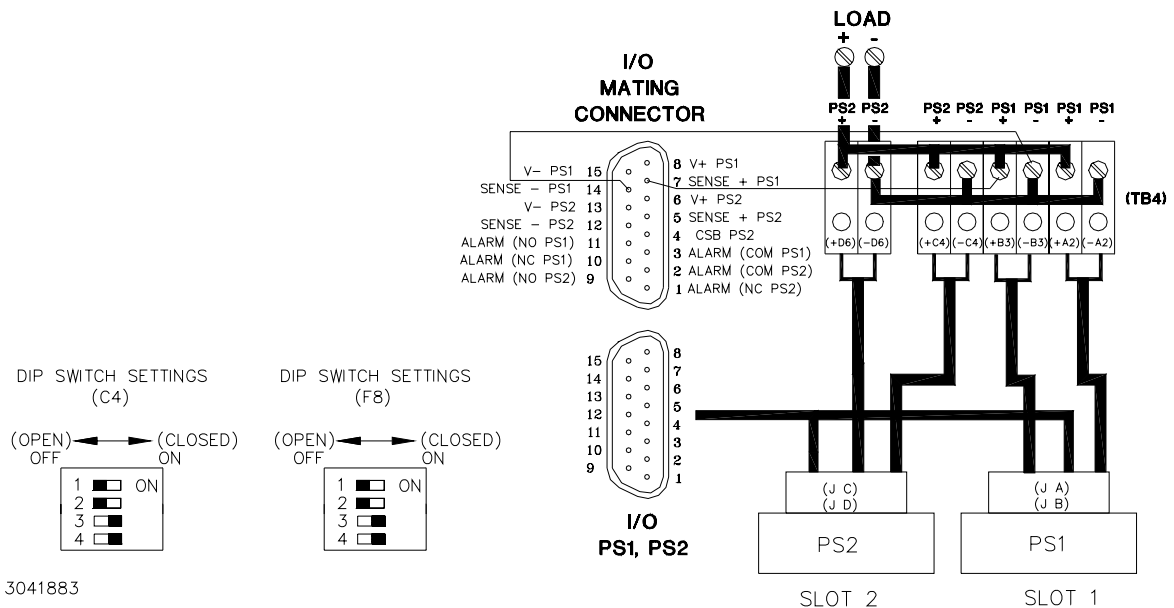

FIGURE 2-6. TYPICAL PARALLEL CONNECTIONS USING EXTERNAL WIRES FOR LOCAL SENSING AND DIP SWITCHES TO PARALLEL SENSE WIRES

2.4.2.3.2 PARALLEL CONFIGURATIONS USING EXTERNAL WIRES TO CONNECT SENSE LINES IN PARALLEL AND EXTERNAL WIRES TO CONFIGURE LOCAL SENSING

Figure 2-7 is a simplified diagram of a typical parallel configuration using local sensing via external wires to connect V(+) to S(+), V(-) to S(-) and jumpers connected to the I/O mating connector to connect the sense leads in parallel. This configuration requires the following:

1. For each supply in parallel set DIP switch positions 1 and 2 to OFF (open) (see Figure 2-1).
2. For each DIP switch between parallel-connected slots (C4 and F8), set DIP switch positions 3 and 4 to OFF (open) (sense leads will be connected in parallel in steps 7 and 8) (see Figure 2-1).
3. For each DIP switch between parallel-connected slots configure position 5 to connect the current share bus by referring to PAR. 2.4.2.2.
4. Configure Positions 6, 7, and 8 (alarms) of each DIP switch per PAR. 2.4.4.
5. Connect wire between I/O mating connector pin Sense (+) and corresponding power supply V (+) terminal at DC OUTPUT terminal block.
6. Connect wire between I/O mating connector pin Sense (-) and corresponding power supply V (-) terminal at DC OUTPUT terminal block.
7. Connect short jumper across I/O mating connector Sense (+) pins.
8. Connect short jumper across I/O mating connector Sense (-) pins.

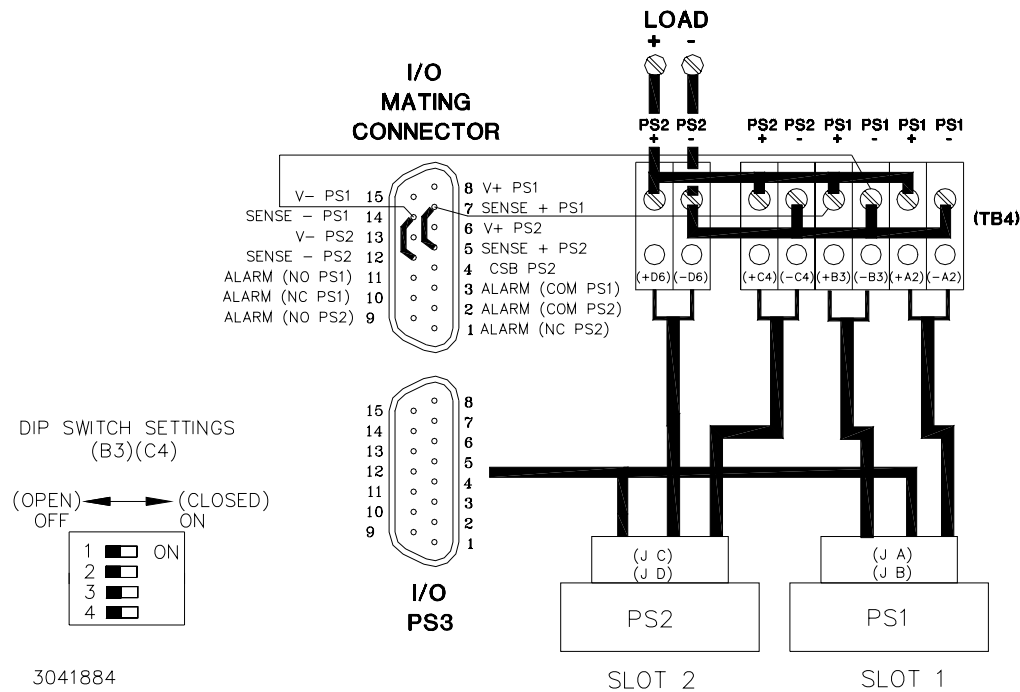
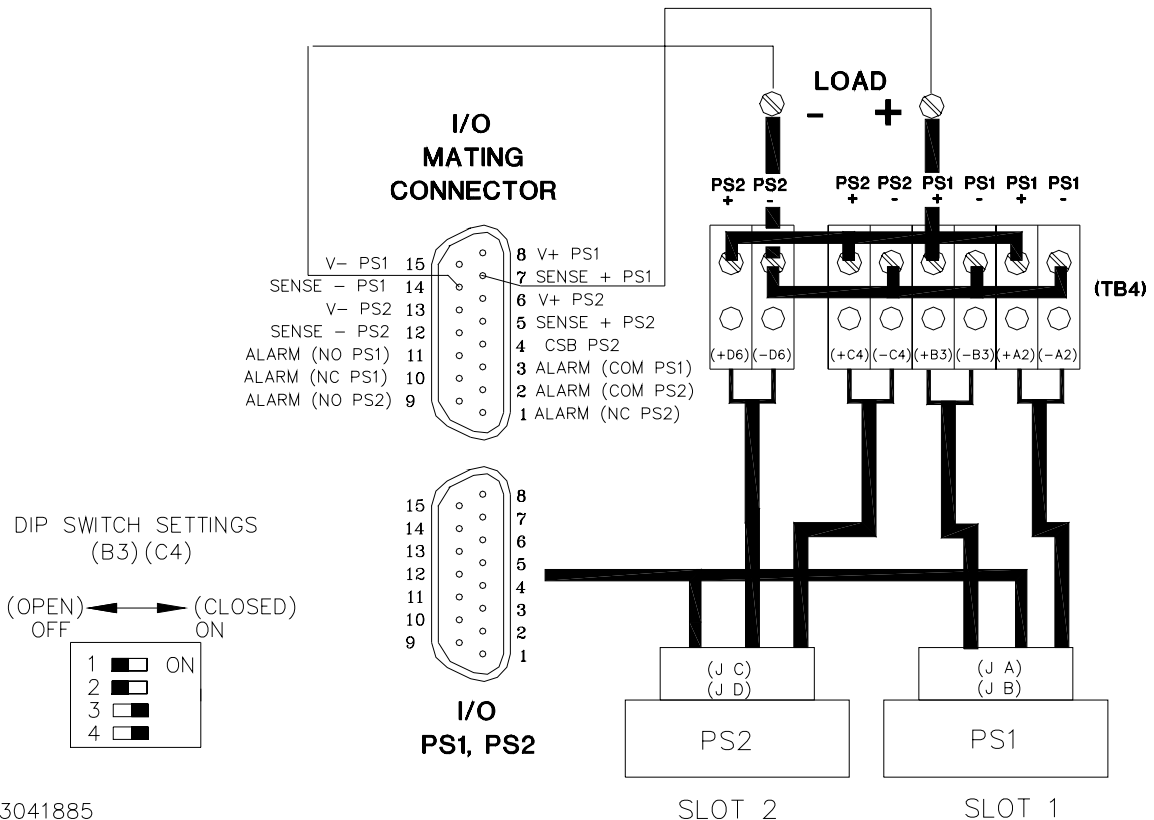

FIGURE 2-7. TYPICAL PARALLEL CONNECTIONS USING EXTERNAL WIRES FOR LOCAL SENSING AND I/O MATING CONNECTOR JUMPERS TO PARALLEL SENSE WIRES

2.4.2.3.3 PARALLEL CONFIGURATIONS USING DIP SWITCHES TO CONNECT SENSE LINES IN PARALLEL AND EXTERNAL WIRES TO CONFIGURE REMOTE SENSING

Figure 2-8 is a simplified diagram of a typical parallel configuration using remote sensing via external wires to connect V(+) to S(+), V(-) to S(-) and DIP switch settings to connect the sense leads in parallel. This configuration requires the following:

1. For each supply in parallel set DIP switch positions 1 and 2 to OFF (open) (see Figure 2-1).
2. For each DIP switch between parallel-connected slots (C4 and F8), set DIP switch positions 3 and 4 to ON (closed) to connect sense leads in parallel (see Figure 2-1).
3. For each DIP switch between parallel-connected slots configure position 5 to connect the current share bus by referring to PAR. 2.4.2.2.
4. Configure Positions 6, 7, and 8 (alarms) of each DIP switch per PAR. 2.4.4.
5. Connect wire from I/O mating connector Sense (+) pin to V (+) at the load.
6. Connect wire from I/O mating connector Sense (-) pin to V (-) at the load.



3041885

FIGURE 2-8. TYPICAL PARALLEL CONNECTIONS, REMOTE SENSING USING DIP SWITCHES TO PARALLEL SENSE WIRES

2.4.2.3.4 PARALLEL CONFIGURATIONS USING EXTERNAL WIRES TO CONNECT SENSE LINES IN PARALLEL AND EXTERNAL WIRES TO CONFIGURE REMOTE SENSING

Figure 2-9 is a simplified diagram of a typical parallel configuration using remote sensing via external wires to connect V(+) to S(+), V(-) to S(-) and jumpers connected to the mating connector to connect the sense leads in parallel. This configuration requires the following:

1. For each supply in parallel set DIP switch positions 1 and 2 to OFF (open) (see Figure 2-1).
2. For each DIP switch between parallel-connected slots (C4 and F8), set DIP switch positions 3 and 4 to OFF (open) (sense leads will be connected in parallel in steps 7 and 8) (see Figure 2-1).
3. For each DIP switch between parallel-connected slots, configure position 5 to connect the current share bus by referring to PAR. 2.4.2.2.
4. Configure Positions 6, 7, and 8 (alarms) of each DIP switch per PAR. 2.4.4.
5. Connect short jumper across I/O mating connector Sense (+) pins.
6. Connect short jumper across I/O mating connector Sense (-) pins.
7. Connect wire from I/O mating connector Sense (+) pin to V (+) at the load.
8. Connect wire from I/O mating connector Sense (-) pin to V (-) at the load.

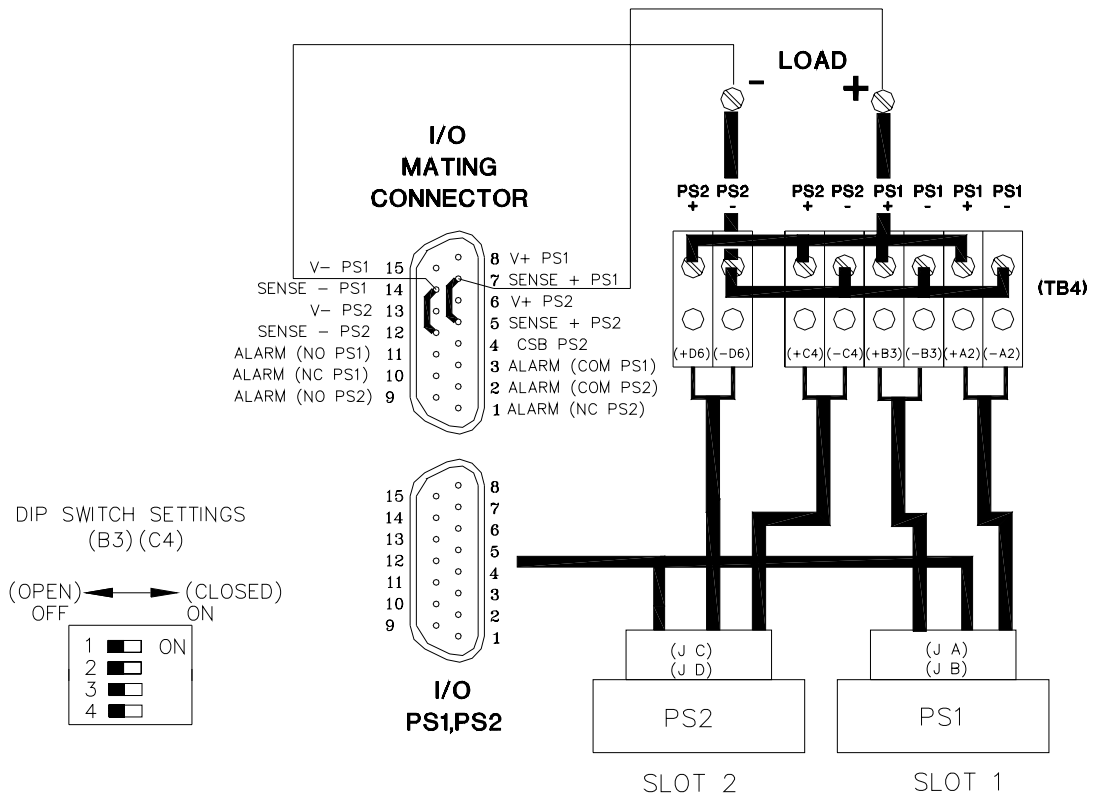

3041886

FIGURE 2-9. TYPICAL PARALLEL CONNECTIONS, REMOTE SENSING USING I/O MATING CONNECTOR JUMPERS TO PARALLEL SENSE WIRES

2.4.3 SERIES OPERATION

HSF power supplies may be connected in series to obtain higher output voltages, however the maximum current must not exceed 35 Amperes (the current carrying capacity of the internal printed circuit board) and is limited to the maximum current of one of the power supplies connected in series. The power supply with the lowest rated value of maximum current establishes the maximum load current allowed. Series configurations can only be accomplished by **external wiring** of the I/O mating connector. Blocking diodes are incorporated in the HSF power supplies. V+ of one supply must be connected to V- of the next supply at the DC OUTPUT terminal block.

DIP switches (positions 1 through 5) *between* series-connected supplies and at both ends of the series-connected group must be set to OFF (open). Sensing can be either local or remote (PAR. 2.4.1.3). Local sensing requires external wiring (PAR.2.4.1.2). Figure 2-10 illustrates PS4, PS3 and PS6 connected in series.

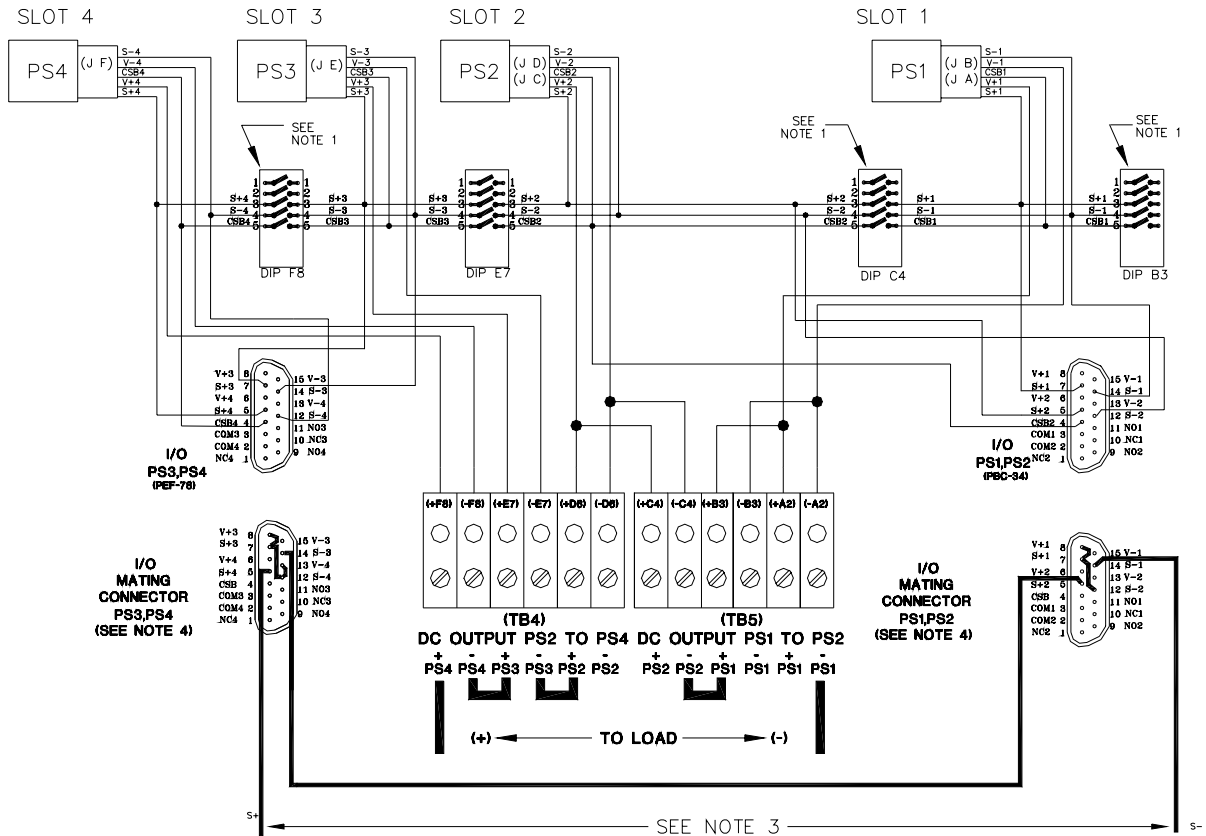

NOTES:

1. DIP SWITCH SETTINGS FOR SERIES OPERATION :
POSITIONS 1 THROUGH 5 OF DIP SWITCHES F8,D5, C4 AND B3 MUST BE SET TO OFF (OPEN).
2. CONNECTIONS TO I/O CONNECTOR ARE INTERNAL AND SHOWN FOR REFERENCE ONLY.
3. S+ AND S- LINES MUST BE CONNECTED TO (+) OUT AND (-) OUT RESPECTIVELY. THIS CAN BE DONE EITHER AT THE DC OUTPUT TERMINALS OR AT THE I/O MATING CONNECTOR (LOCAL SENSING) OR AT THE LOAD (REMOTE SENSING); REFER TO PAR.2.4.1.3.
4. I/O MATING CONNECTOR VIEWED FROM FRONT (MATING FACE) FOR EASE OF LOCATING CORRESPONDING I/O CONNECTOR PINS.

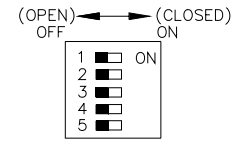

DIP SWITCH SETTINGS (B3,C4,F8)

3042008

FIGURE 2-10. SERIES CONFIGURATION, SIMPLIFIED DIAGRAM

2.4.4 ALARM CONFIGURATIONS

The HSF Power Supplies each provide a normally closed (N.C.) and normally open (N.O.) line referenced to common (COM) for use as an alarm at the users discretion. The N.C. line opens upon failure, the N.O. line closes upon failure. The RA 19-4B is configured at the factory for independent operation of these lines. It is possible to configure these alarm lines to allow multiple power supplies to provide a failure indication using the N.O. (close on failure) lines, N.C (open on failure) lines, or both. Each alarm circuit can be configured in two ways: either by internal DIP switches or by external wiring of the I/O mating connector.

CAUTION: The user is responsible for ensuring that the alarm circuit does not exceed DIP switch specifications: 100mA, 50V d-c, maximum.

2.4.4.1 N.O. ALARM LINE (CLOSE ON FAILURE)

The N.O. and COM line of each HSF supply provide a closed contact (short circuit) upon failure. To configure multiple power supplies so that a failure of any supply produces a failure indication, it is necessary to connect the N.O. lines in parallel and the COM lines in parallel.

2.4.4.1.1 CLOSE ON FAILURE USING INTERNAL DIP SWITCHES

Close on failure for multiple power supplies can be accomplished by setting DIP switch positions 6 and 7 to ON (closed). associated with each adjacent slot included in the alarm circuit. For example, for PS1 and PS2, set DIP switch 2, positions 6 and 7 to ON (closed). The failure indication (short circuit) will be present across both N.O.1 and COM1, and N.O.2 and COM2. Figure 2-11 is a simplified diagram illustrating a close on failure alarm configuration for four power supplies using internal DIP switches.

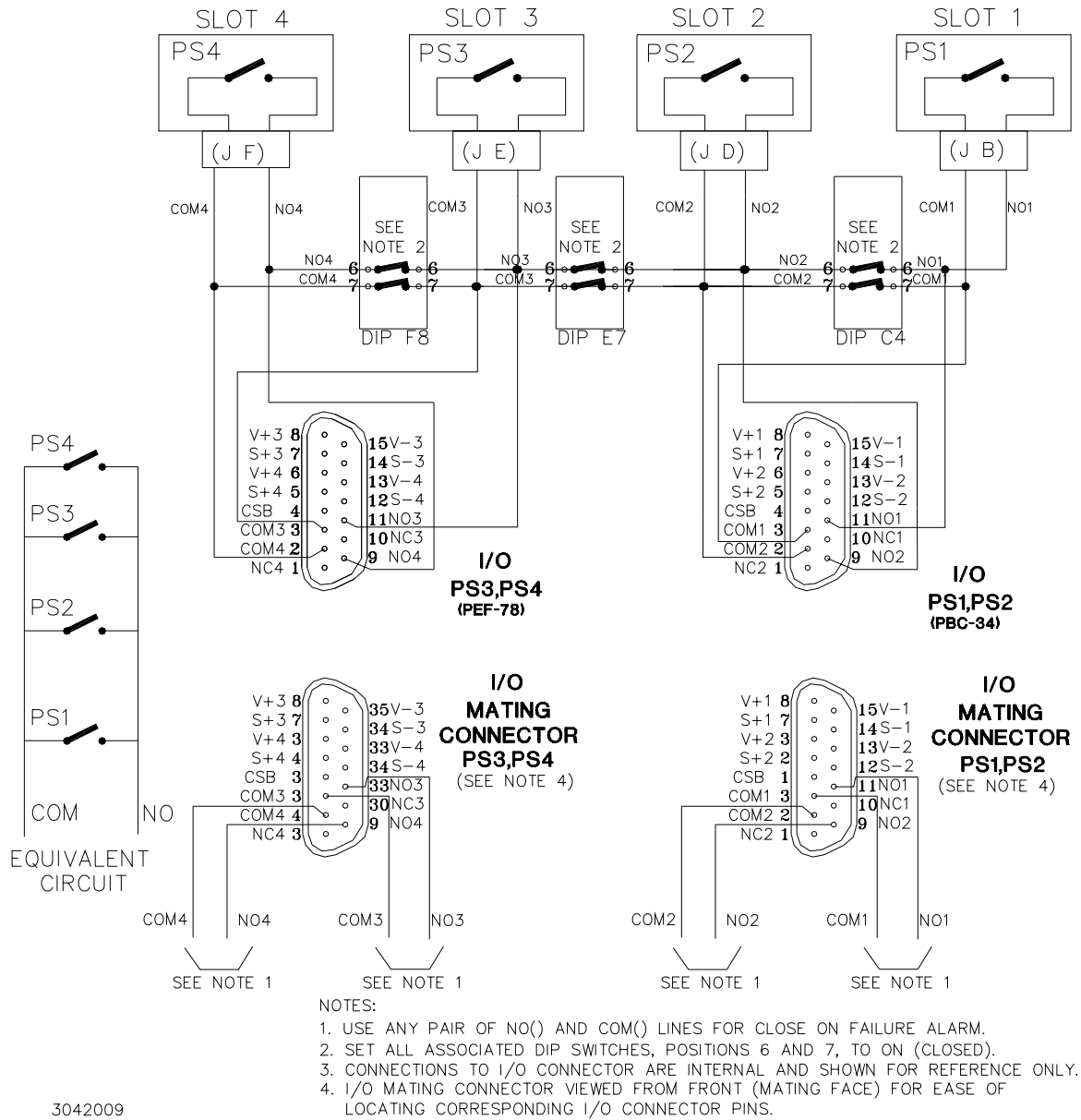

3042009

FIGURE 2-11. CLOSE ON FAILURE ALARM CONFIGURATION USING INTERNAL DIP SWITCHES, SIMPLIFIED DIAGRAM

2.4.4.1.2 CLOSE ON FAILURE USING EXTERNAL WIRING AT I/O MATING CONNECTOR

Close on failure for multiple power supplies can be accomplished by wiring N.O. and COM in parallel at the I/O mating connector. DIP switches associated with slots included in the alarm circuit must have positions 6 and 7 set to OFF (open). The failure indication (short circuit) will be present across any pair of N.O. and COM lines. Figure 2-12 is a simplified diagram illustrating a close on failure alarm configuration for four power supplies using external wiring at the I/O mating connector.

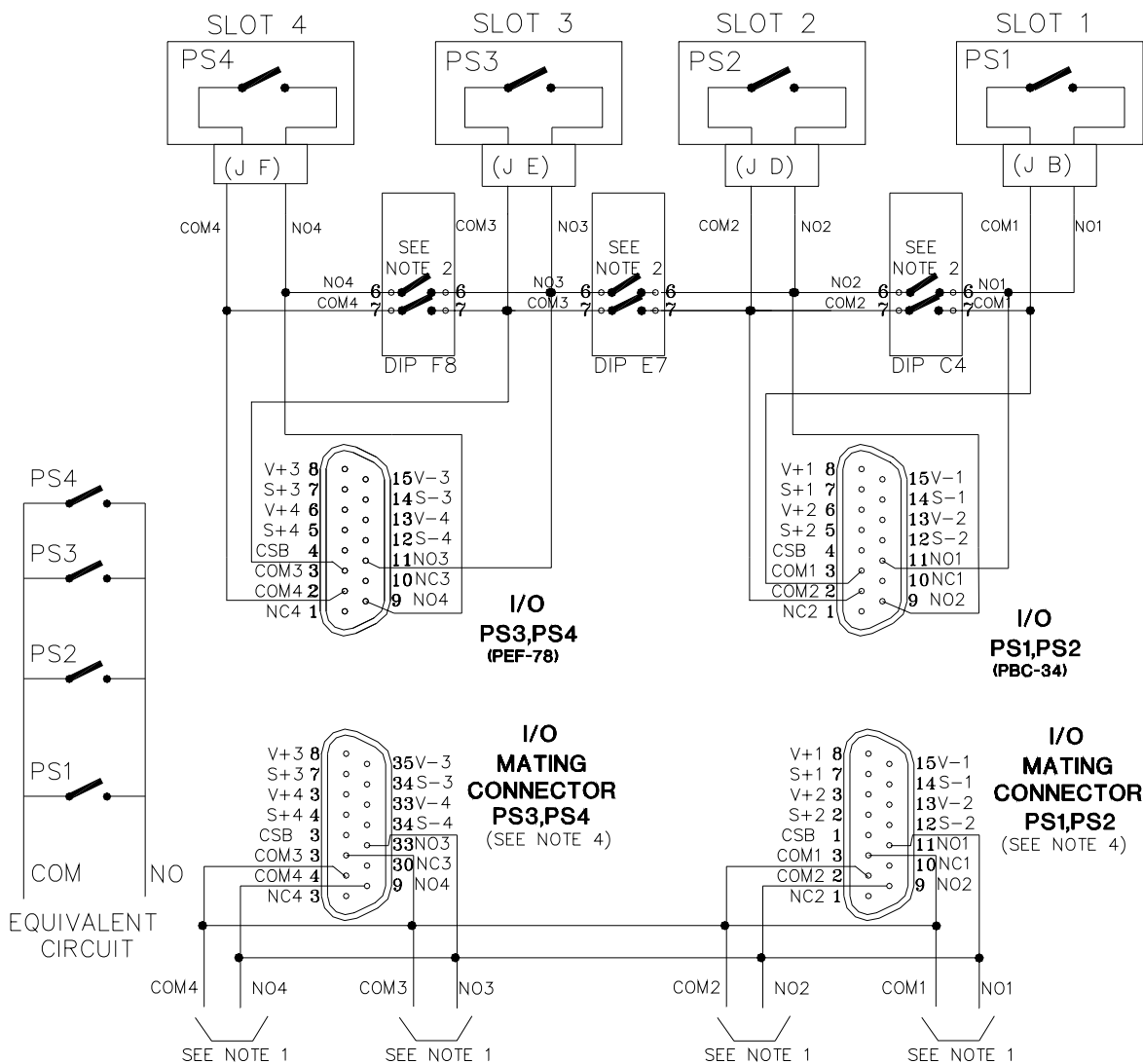

- NOTES:
1. USE ANY PAIR OF NO() AND COM() LINES FOR CLOSE ON FAILURE ALARM.
 2. SET ALL ASSOCIATED DIP SWITCHES, POSITIONS 6 AND 7, TO ON (CLOSED).
 3. CONNECTIONS TO I/O CONNECTOR ARE INTERNAL AND SHOWN FOR REFERENCE ONLY.
 4. I/O MATING CONNECTOR VIEWED FROM FRONT (MATING FACE) FOR EASE OF LOCATING CORRESPONDING I/O CONNECTOR PINS.

3042010

FIGURE 2-12. CLOSE ON FAILURE ALARM CONFIGURATION USING EXTERNAL WIRING AT I/O MATING CONNECTOR, SIMPLIFIED DIAGRAM

2.4.4.2 N.C. ALARM LINE (OPEN ON FAILURE)

The N.C and COM line of each HSF supply provide an open contact (open circuit) upon failure. To configure multiple power supplies so that a failure of any supply produces a failure indication, it is necessary to connect the N.C. line of one, with the COM line of the next power supply, in series.

2.4.4.2.1 OPEN ON FAILURE USING INTERNAL DIP SWITCHES

The open on failure alarm for multiple power supplies is accomplished by setting the associated DIP switch, position 8, to ON (closed) for each slot included in the alarm circuit as indicated in Figure 2-13. Setting DIP switch position 8 to ON (closed) connects the N.C. line to the COM line of the adjacent power supply. Figure 2-13 illustrates an open on failure alarm configuration for four power supplies using internal DIP switch settings.

CAUTION: The user is responsible for ensuring that the alarm circuit does not exceed DIP switch specifications: 100mA, 50V d-c, maximum.

To configure PS1, PS2 and PS3 as open on failure, set position 8 of DIP switch for slot 2 (C4) and slot 3 (F8) to ON (closed). The failure indication (open circuit) will be present across N.C.3 and COM 1.

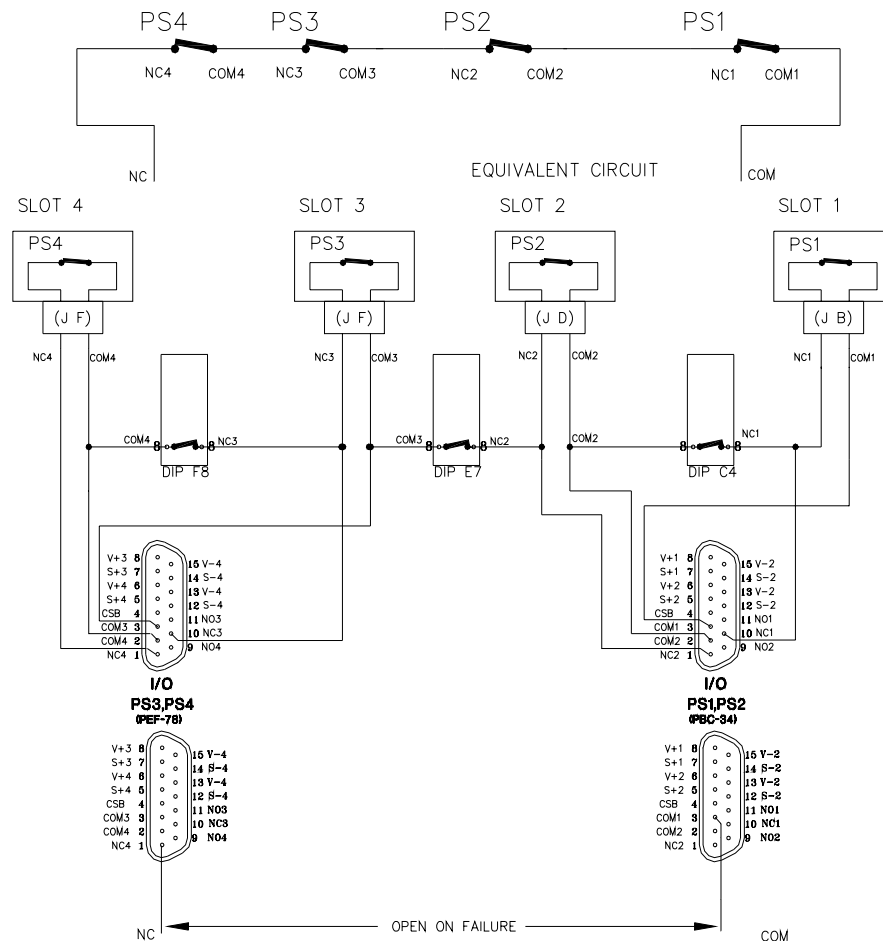

NOTES:

1. SET POSITION 8 OF SPECIFIED DIP SWITCHES TO ON (CLOSED).
2. CONNECTIONS TO I/O CONNECTOR ARE INTERNAL AND SHOWN FOR REFERENCE ONLY.
3. I/O MATING CONNECTOR VIEWED FROM FRONT (MATING FACE) FOR EASE OF LOCATING CORRESPONDING I/O CONNECTOR PINS.

3042011

FIGURE 2-13. OPEN ON FAILURE ALARM CONFIGURATION USING INTERNAL DIP SWITCHES, SIMPLIFIED DIAGRAM

2.4.4.2.2 OPEN ON FAILURE USING EXTERNAL WIRING OF I/O MATING CONNECTOR

Figure 2-14 illustrates an open on failure alarm configuration using external wiring of the I/O mating connectors for four power supplies. It is necessary to set DIP switch position 8 to OFF (open) for each slot included in the open on failure alarm circuit.

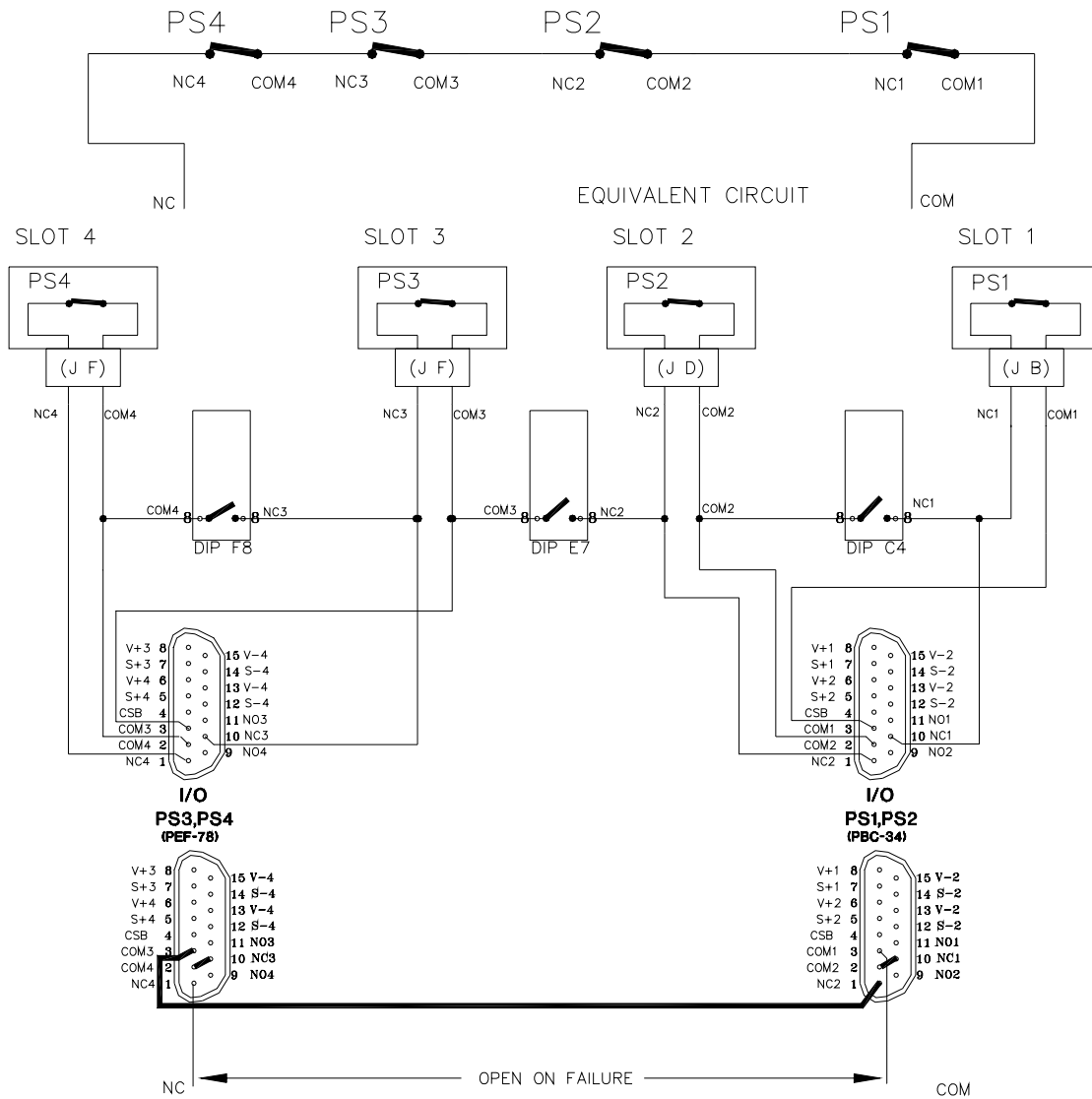

NOTES:

1. SET POSITION 8 OF SPECIFIED DIP SWITCHES TO OFF (CLOSED).
2. CONNECTIONS TO I/O CONNECTOR ARE INTERNAL AND SHOWN FOR REFERENCE ONLY.
3. I/O MATING CONNECTOR VIEWED FROM FRONT (MATING FACE) FOR EASE OF LOCATING CORRESPONDING I/O CONNECTOR PINS.

3042012

FIGURE 2-14. OPEN ON FAILURE ALARM CONFIGURATION USING EXTERNAL WIRING AT I/O MATING CONNECTOR, SIMPLIFIED DIAGRAM

2.5 TERMINATIONS

All input, output and control terminations are located on the rear panel of the rack adapter (see Figure 1-4).

2.6 COOLING

The HSF power supplies mounted within the rack adapter are maintained within their operating temperature range by means of convection cooling. ALL OPENINGS AROUND THE RACK ADAPTER CASE MUST BE KEPT CLEAR OF OBSTRUCTION TO ENSURE PROPER AIR CIRCULATION. Care must be taken that the ambient temperature, which is the temperature of the air immediately surrounding the rack adapter, does not rise above the specified limits for the operating load conditions of the installed HSF power supplies. Kepeco recommends providing additional space above and below the rack adapter where possible when the rack adapter is fully populated.

2.7 INSTALLATION (Refer to "Mechanical Outline Drawing," Figure 1-5.)

The rack adapter mounts directly to EIA standard 19" racks via the two mounting ears; two screws are required per mounting ear for proper support.

Provide adequate clearance around case and ensure that the temperature immediately surrounding the unit does not exceed the maximum specified ambient temperature for the operating conditions of the installed power supplies.

CAUTION

RACK ADAPTER SHOULD BE MOUNTED BEFORE INSTALLING POWER SUPPLIES.

2.8 WIRING INSTRUCTIONS

Interconnections between an a-c power source and a stabilized power supply, and between the power supply and its load are as critical as the interface between other types of electronic equipment. If optimum performance is expected, certain rules for the interconnection of source, power supply and load must be observed by the user. These rules are described in detail in the following paragraphs and in the operating instructions for HSF Series power supplies.

2.8.1 SAFETY GROUNDING

Local, national and international safety rules dictate the grounding of the metal cover and case of any instrument connected to the a-c power source, when such grounding is an intrinsic part of the safety aspect of the instrument. The instructions below suggest wiring methods which comply with these safety requirements; however, in the event that the specific installation for the power system involves differences with the recommended wiring, it is the customer's responsibility to ensure that all applicable electric codes for safety grounding requirements are met.

2.8.2 SOURCE POWER CONNECTIONS

CAUTION

THE SERIES RA 19-(X)B DOES NOT INCORPORATE ANY SAFETY INTERRUPT DEVICES. PROTECTION OF INPUT WIRING REQUIRES USER-CONFIGURED SAFETY INTERRUPTS.

When used in conjunction with Kepco HSF series power supplies, these rack adapters can be operated from single phase 95-264V a-c or 125-370V d-c source power without adjustment or modification. Source power is applied to two 3-terminal terminal blocks at the rear panel and distributed as indicated in Figure 1-3. Wires must be sized according to expected current. Wire size range is 20-10 AWG; torque to 6 lb-in (0.6N•M) maximum. The terminal positions are labeled L, N, and G. Their functions are as follows:

- **Terminal G (Ground)** is the safety ground connection for the Series RA 19-(X)B. It is connected to the Series RA 19-(X)B chassis and to the safety ground terminal of the input power connector for each of the power supply mounting positions via the PCB backplane. Terminal G must be connected to safety ground in order to ensure proper grounding of the HSF power supplies.
- **Terminals L (Line Phase) and N (Neutral)** are connected to the input power entry connectors. Source power is provided to the power supplies indicated by the label on the rear panel. The source power connectors are independent of each other, allowing the user complete flexibility in wiring for common or redundant input power configurations.

The following standard wiring configuration is recommended by Kepco as being compliant with applicable national and international safety standards. Please consult local electrical codes for wire current ratings and other specific requirements:

- Connect Terminal G of each Series RA 19-(X)B input power terminal block to safety ground
- Connect a separate wire pair from each side of the input power to the L/N terminal pair of the input power terminal block.
- Where 115V a-c source power is used, Kepco recommends the use of the line cords, P/N 118-0506 supplied (North American style plug, 15A maximum, 6 ft. long).
- Wire size is determined by the maximum rated source current for each HSF power supply and the number of power supplies installed. For lower system power configurations, smaller wire can be used; contact Kepco Applications Engineering for assistance.

2.8.3 CONTROL SIGNAL CONNECTIONS

Access to the control signal (I/O) connector for each HSF power supply is provided via the 15-pin D-subminiature connectors on the rear panel of the rack adapter (see Figure 1-4). Two mating connectors (Kepco P/N 142-0449) are provided in a plastic bag. Consult PAR. 2.4 and the HSF operator's manual for instructions on wiring and use of these control lines.

2.8.4 OUTPUT LOAD CONNECTIONS

Load connections to the rack adapters are achieved via two terminal blocks located on the backplate assembly. Wires must be sized according to expected current. Wire size range is 20-10 AWG; torque to 6 lb-in (0.6N•M) maximum. (Sensing connections are made through the I/O mating connector, PAR. 2.4.1)

NOTE!

REGARDLESS OF OUTPUT CONFIGURATION, OUTPUT SENSE LINES MUST BE PROPERLY CONNECTED FOR OPERATION.

2.8.4.1 PARALLEL/REDUNDANT OPERATION



Removal of an HSF power supply from a “live” system must be done only by authorized service personnel after HSF power switch is set to OFF. Dangerous voltages may be accessible through the open slot after a power supply is removed.

Identical HSF power supplies can be connected in parallel to provide redundant operation or increased output current to a common load. Maximum output current for each terminal pair of the DC OUTPUT terminal blocks is 35 Amperes. Connect (+) to (+) and (–) to (–) at the DC OUTPUT terminal block (see Figure 2-5).

NOTE: Verify that the sense lines and current share bus are configured per PAR. 2.4.2. An external bus is required where current exceeds 35 Amperes.

2.8.4.2 SERIES/INDEPENDENT OPERATION

The rack adapter can be used for either independent or series operation of HSF power supplies; it is factory configured for independent operation using local sensing. To select remote sensing, refer to PAR. 2.4.1.3.

For series operation, connect (+) and (–) terminals at the DC OUTPUT terminal block of power supplies to be connected in series (see Figure 2-10). The HSF power supplies are equipped with blocking diodes which allow series operation without further modification. The RA 19-(X)B Series rack adapter is designed to safely handle a maximum output voltage of 500 Volts.

2.8.4.3 MIXED OPERATION

The design of the Series RA 19-(X)B rack adapters permits the user to configure HSF power supplies for almost any combination of independent, series and parallel operation, both within a single rack adapter and between different RA 19-(X)B rack adapters, within the limits of the HSF operation envelope and the current and voltage ratings specified in PAR.s 2.8.4.1 and 2.8.4.2. The user must ensure that the requirements for each configuration stated above are met. If any questions or problems arise, the user is encouraged to contact the Kepco Applications Engineering group for technical assistance.

2.9 INSTALLING/REMOVING HSF POWER SUPPLIES

**WARNING**

Removal of an HSF power supply from a “live” system must be done only by authorized service personnel after HSF power switch is set to OFF. Dangerous voltages may be accessible through the open slot after a power supply is removed.

Refer to Figure 1-1, for proper slot positions applicable to the RA 19-4B Rack Adapter. Insert HSF power supply in selected slot until power supply front panel is flush with rack adapter chassis and secure with two phillips screws on power supply.

2.10 SHIPPING

The rack adapter may be shipped with power supplies installed *only* after the HSF power supplies have been securely fastened to the rack adapter (PAR. 2.9). Contact Kepco Applications Engineering if further assistance is required.

You must register your product to comply with the terms of the warranty. Either fill out the form below and mail or fax to Kepco, or for rapid on-line registration go to:

<http://www.kepcopower.com/warranty.htm>

PRODUCT PURCHASED:

Model Number) _____

Serial Number _____

PURCHASE INFORMATION:

Date Purchased: _____

Date Received: _____

REQUEST ADDITIONAL INFORMATION

Send complete Catalog

Have Sales Engineer Call

Contact via: E-Mail Telephone Fax S-mail

REGISTER TO:

Registered by: _____

Company Name: _____

Street: _____

City: _____

State: _____

Country: _____

Zip: _____

E-mail: _____

FAX: _____

Phone: _____

WHAT INFLUENCED YOUR CHOICE OF THIS POWER SUPPLY?

Previous Experience (which Kepco Models do you have?)

Magazines (which ones?) _____

Trade Shows (which ones?) _____

Directory? _____

Kepco Catalog or Brochure? _____

Sales Representative?

Web Site

Other (please explain): _____

What products would you like to see Kepco make?

CUT HERE

Kepco 5 Year Warranty

This is to certify that we, KEPCO, INC., (hereinafter called "Company"), Flushing, NY 11352 USA, warrants for a period of FIVE YEARS, this instrument known as:

MODEL: _____

SERIAL NO. _____

The Company's products are warranted for a period of five years from date of delivery to be free from defects in materials and workmanship and to conform to the specifications furnished or approved by the Company. Liability under this warranty shall be limited to the repair or replacement of any defective product at Company's option.

If any defect within this warranty appears within the warranty period, the Purchaser shall promptly notify the Company in writing. No material will be accepted for repair or replacement without written authorization of the Company.

Upon such authorization, and in accordance with instructions of the Company, parts or materials for which replacement is requested shall be returned to the Company for examination, with shipping charges prepaid by the Purchaser. Final determination as to whether a product is actually defective rests with the Company.

This warranty does not extend to any product which has been subjected to misuse, neglect, accident, improper installation, or use in violation of instructions furnished by the Company. The warranty does not extend to, or apply to, any unit which has been repaired or altered outside of the Company's factory by persons not expressly approved by the Company.

THE WARRANTY HEREIN CONTAINED IS IN LIEU OF AND EXCLUDES ALL OTHER WARRANTIES, EXPRESS, IMPLIED OR STATUTORY, INCLUDING WITHOUT LIMITATION THE WARRANTY OF MERCHANTABILITY.

THIS KEPCO PRODUCT IS WARRANTED FOR FIVE YEARS!

KEPCO, INC. • 131-38 SANFORD AVENUE, FLUSHING,
NY 11352 USA • Tel. 718-461-7000 • Fax. 718-767-1102
E-mail: hq@kepcopower.com • URL: <http://www.kepcopower.com>



FOLD HERE

Please
place
stamp
here

KEPCO, INC.

131-38 SANFORD AVE.
FLUSHING, NY 11352 USA

CUT HERE